

## Supplemental Problems



New York, New York   Columbus, Ohio   Chicago, Illinois   Peoria, Illinois   Woodland Hills, California

A Glencoe Program

# PHYSICS

## Principles and Problems

### Student Edition

### Teacher Wraparound Edition

### Teacher Chapter Resources

- Mini Lab Worksheets
- Physics Lab Worksheets
- Study Guide
- Section Quizzes
- Reinforcement
- Enrichment
- Transparency Masters
- Transparency Worksheets
- Chapter Assessment

### Teacher Classroom Resources

- Teaching Transparencies
- Laboratory Manual, Student Edition
- Laboratory Manual, Teacher Edition
- Probeware Laboratory Manual, Student Edition
- Probeware Laboratory Manual, Teacher Edition
- Forensics Laboratory Manual, Student Edition

Forensics Laboratory Manual, Teacher Edition

- Supplemental Problems
- Additional Challenge Problems
- Pre-AP/Critical Thinking Problems
- Physics Test Prep: Studying for the End-of-Course Exam, Student Edition
- Physics Test Prep: Studying for the End-of-Course Exam, Teacher Edition
- Connecting Math to Physics
- Solutions Manual

### Technology

- Answer Key Maker
- ExamView® Pro
- Interactive Chalkboard
- McGraw-Hill Learning Network
- StudentWorks™ CD-ROM
- TeacherWorks™ CD-ROM
- [physicspp.com](http://physicspp.com) Web site



The McGraw-Hill Companies

Copyright © by The McGraw-Hill Companies, Inc. All rights reserved. Permission is granted to reproduce the material contained herein on the condition that such material be reproduced only for classroom use; be provided to students, teachers, and families without charge; and be used solely in conjunction with the **Physics: Principles and Problems** program. Any other reproduction, for use or sale, is prohibited without prior written permission of the publisher.

Send all inquiries to:  
Glencoe/McGraw-Hill  
8787 Orion Place  
Columbus, Ohio 43240

ISBN 0-07-865896-9

Printed in the United States of America

1 2 3 4 5 6 7 8 9 045 09 08 07 06 05 04

# Contents

To the Teacher . . . . .	iv		
A Physics Toolkit . . . . .	1	Fundamentals of Light . . . . .	31
Representing Motion . . . . .	3	Reflection and Mirrors . . . . .	33
Accelerated Motion . . . . .	5	Refraction and Lenses . . . . .	35
Forces in One Dimension . . . . .	7	Interference and Diffraction . . . . .	37
Forces in Two Dimensions . . . . .	9	Static Electricity . . . . .	39
Motion in Two Dimensions . . . . .	11	Electric Fields . . . . .	41
Gravitation . . . . .	13	Current Electricity . . . . .	43
Rotational Motion . . . . .	15	Series and Parallel Circuits . . . . .	45
Momentum and Its Conservation . . . . .	17	Magnetic Fields . . . . .	47
Energy, Work, and Simple Machines . . . . .	19	Electromagnetic Induction . . . . .	49
Energy and Its Conservation . . . . .	21	Electromagnetism . . . . .	51
Thermal Energy . . . . .	23	Quantum Theory . . . . .	53
States of Matter . . . . .	25	The Atom . . . . .	55
Vibrations and Waves . . . . .	27	Solid-State Electronics . . . . .	57
Sound . . . . .	29	Nuclear Physics . . . . .	59
		Answer Key . . . . .	61

# To the Teacher

*Supplemental Problems* features additional practice problems to accompany each chapter of *Physics: Principles and Problems*. This book contains two pages of additional practice problems for each chapter. The types of problems and the order in which they appear in this supplement mirror the corresponding chapter. As a result, students will have numerous opportunities to sharpen their problem-solving skills and strengthen their understanding of essential concepts. These problems can be assigned as extra practice or as extra credit.

An Answer Key provides fully worked-out solutions and complete answers to each problem and question. The Answer Key is found in the back of this book.

## CHAPTER

## 1

## Supplemental Problems

## A Physics Toolkit

- Express the following quantities in scientific notation.
  - 4501 m
  - 75,000 km
  - 6438 g
  - 0.6438 g
  - 0.00048 s
  - 24 h
- Convert each of the following quantities as indicated.
  - 3600 cm to meters
  - 5000 m to kilometers
  - 5000 km to meters
  - 15 kg to grams
  - 1.5 mg to grams
- Write the conversion factor for each of the following conversions.
  - mL to liters
  - kg to grams
  - nm to meters
  - $\mu\text{g}$  to grams
  - $\text{km/s}^2$  to  $\text{m/s}^2$
- Calculate each of the following and express the results in scientific notation with the correct number of significant digits and correct units.
  - $4.098 \text{ m} + 56.03 \text{ m} + 10.2 \text{ m} =$
  - $603 \text{ km}/1000 \text{ s} =$
  - $4.000 \text{ m} \times 20.30 \text{ m} =$
  - $5.5 \times 10^{-1} \text{ mm} + 2.0 \times 10^{-3} \text{ mm} =$
- On Earth, the force of gravity on an object is expressed as  $F = m \times g$ , where  $F$  is the force applied on the object,  $m$  is the mass of the object, and  $g$  is the gravitational constant, which is  $9.80 \text{ m/s}^2$ .
  - What are the units of the force of gravity if the mass is expressed in kilograms?
  - Calculate the gravitational force on an object with a mass of 10.32 kg.
- State the number of significant digits in each of the following measurements and express the value in scientific notation.
  - 903 kg
  - 600.00 m
  - 0.0030 mm
  - $8.030 \times 10^{-4} \text{ J}$
  - $38.60 \times 10^{-3} \text{ m/s}$
- The figure below shows a graph of the mass of a substance compared to its volume.
  - What type of relationship is mass versus volume?
  - What is the volume of 6.0 kg of the substance?
  - What is the mass of each liter of the substance?

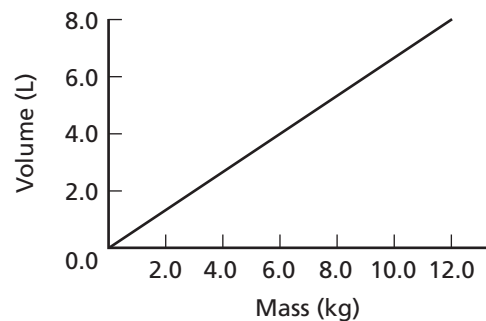

# 1 Supplemental Problems

continued

8. The surface of a rectangular table is measured as 2.24 m long and 1.103 m wide.
- Calculate the perimeter of the tabletop.
  - Calculate the area of the tabletop.
  - What is the area of the tabletop, expressed in square centimeters?
9. As a pump transfers water into a cylindrical tank, the mass of water in the tank is measured on a balance. **Table 1-1** shows the mass of water in the tank and its depth.
- Plot the values given in the table and draw a curve that best fits all the points.
  - Describe the resulting curve.
  - Write an equation relating the depth of water in the tank to the mass of water.
  - What is the slope of the line in your graph?
  - Why is the value for the mass of water measured at 40 cm not exactly twice the value measured at 20 cm?

Depth of Water (cm)	Mass of Water (kg)
10	75
20	149
30	225
40	302
50	376
60	453

10. A student measures the mass of a standard set of calibration weights on a triple-beam balance and an electronic balance, obtaining the data in **Table 1-2**.
- Which set of results is more precise? Explain your answer.
  - Which set of results is more accurate? Explain your answer.

Standard Value	Triple-Beam Balance	Electronic Balance
1.000 g	1.001 g	1.1033 g
2.000 g	2.002 g	2.1033 g
3.000 g	3.001 g	3.1034 g
5.000 g	5.000 g	5.1033 g

11. Add or subtract as indicated. Make sure that your answers contain the correct number of significant digits.
- $0.00039 \text{ mm} + 0.0025 \text{ mm}$
  - $2103 \text{ s} - 2.4 \text{ s}$
  - $2.3 \times 10^{-4} \text{ kg} + 6.7 \times 10^{-3} \text{ kg}$
  - $5.85 \times 10^3 \text{ m} - 5.2 \times 10^2 \text{ m}$
12. Multiply or divide as indicated. Make sure your answers contain the correct number of significant digits.
- $(2.21 \text{ kg})(100.0 \text{ m/s}^2)$
  - $\frac{3.3 \times 10^{-5} \text{ m}}{6.55 \times 10^{-6} \text{ s}}$
  - $\frac{200.0 \text{ cm}^2}{1.23 \text{ cm}}$
  - $(7.89 \times 10^4 \text{ km})(3 \times 10^2 \text{ km})$

## CHAPTER

## 2

## Supplemental Problems

## Representing Motion

1. An airplane travels at a constant speed, relative to the ground, of 900.0 km/h.
  - a. How far has the airplane traveled after 2.0 h in the air?
  - b. How long does it take for the airplane to travel between City A and City B if the cities are 3240 km apart?
  - c. If a second plane leaves 1 h after the first, and travels at 1200 km/h, which flight will arrive at City B first?
2. You and your friend start jogging around a  $2.00 \times 10^3$ -m running track at the same time. Your average running speed is 3.15 m/s, while your friend runs at 3.36 m/s. How long does your friend wait for you at the finish line?

3. The graph to the right shows the distance versus time for two cars traveling on a straight highway.

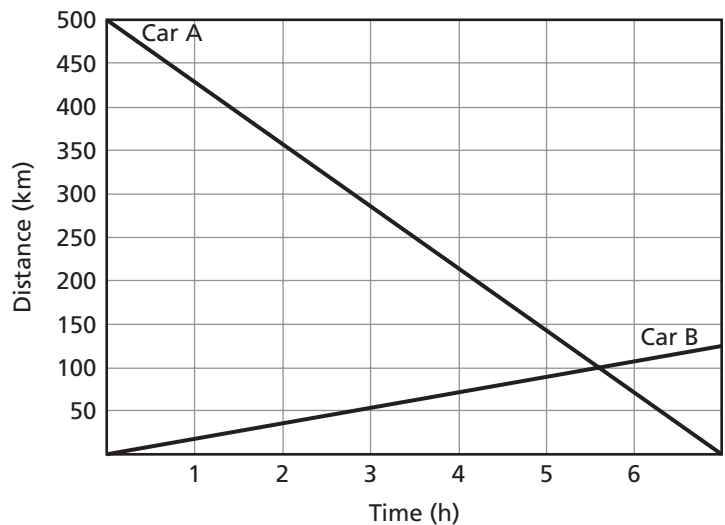

- a. What can you determine about the relative direction of travel of the cars?
  - b. At what time do they pass one another?
  - c. Which car is traveling faster? Explain.
  - d. What is the speed of the slower car?
4. You drop a ball from a height of 2.0 m. It falls to the floor, bounces straight upward 1.3 m, falls to the floor again, and bounces 0.7 m.
  - a. Use vector arrows to show the motion of the ball.
  - b. At the top of the second bounce, what is the total distance that the ball has traveled?
  - c. At the top of the second bounce, what is the ball's displacement from its starting point?
  - d. At the top of the second bounce, what is the ball's displacement from the floor?
5. You are making a map of some of your favorite locations in town. The streets run north-south and east-west and the blocks are exactly 200 m long. As you map the locations, you walk three blocks north, four blocks east, one block north, one block west, and four blocks south.
  - a. Draw a diagram to show your route.
  - b. What is the total distance that you traveled while making the map?

## 2 Supplemental Problems

continued

- c. Use your diagram to determine your final displacement from your starting point.
- d. What vector will you follow to return to your starting point?
6. An antelope can run 90.0 km/h. A cheetah can run 117 km/h for short distances. The cheetah, however, can maintain this speed only for 30.0 s before giving up the chase.
- a. Can an antelope with a 150.0-m lead outrun a cheetah?
- b. What is the closest that the antelope can allow a cheetah to approach and remain likely to escape?

7. The position-time graph to the right represents the motion of three people in an airport moving toward the same departure gate.
- a. Which person travels the farthest during the period shown?
- b. Which person travels fastest by riding a motorized cart? How can you tell?
- c. Which person starts closest to the departure gate?
- d. Which person appears to be going to the wrong gate?

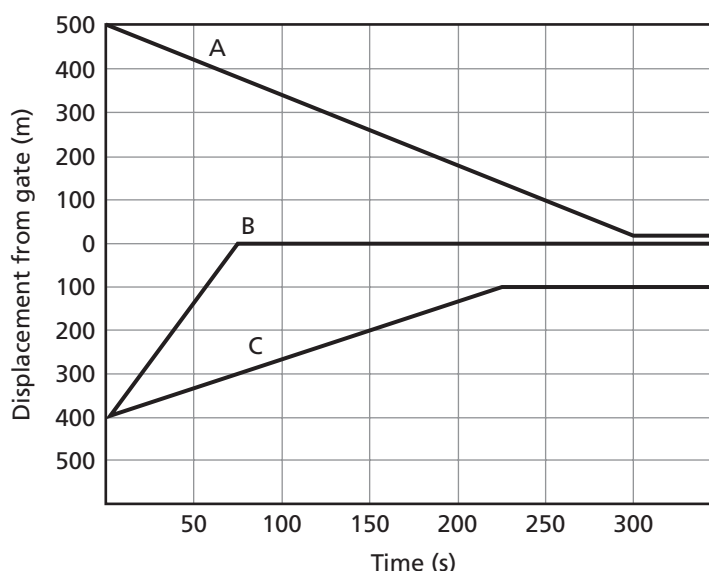

8. A radio signal takes 1.28 s to travel from a transmitter on the Moon to the surface of Earth. The radio waves travel at  $3.00 \times 10^8$  m/s. What is the distance, in kilometers, from the Moon to Earth?
9. You start to walk toward your house eastward at a constant speed of 5.0 km/h. At the same time, your sister leaves your house, driving westward at a constant speed of 30.0 km/h. The total distance from your starting point to the house is 3.5 km.
- a. Draw a position-time graph that shows both your motion and your sister's motion.
- b. From the graph, determine how long you travel before you meet your sister.
- c. How far do you travel in that time?
10. A bus travels on a northbound street for 20.0 s at a constant velocity of 10.0 m/s. After stopping for 20.0 s, it travels at a constant velocity of 15.0 m/s for 30.0 s to the next stop, where it remains for 15.0 s. For the next 15.0 s, the bus continues north at 15.0 m/s.
- a. Construct a  $d$ - $t$  graph of the motion of the bus.
- b. What is the total distance traveled?
- c. What is the average velocity of the bus for this period?



## CHAPTER

## 3

## Supplemental Problems

## Accelerated Motion

1. Use the velocity-time graph below to calculate the velocity of the object whose motion is plotted on the graph.
  - a. What is the acceleration between the points on the graph labeled A and B?
  - b. What is the acceleration between the points on the graph labeled B and C?
  - c. What is the acceleration between the points on the graph labeled D and E?
  - d. What is the total distance that the object travels between points B and C?

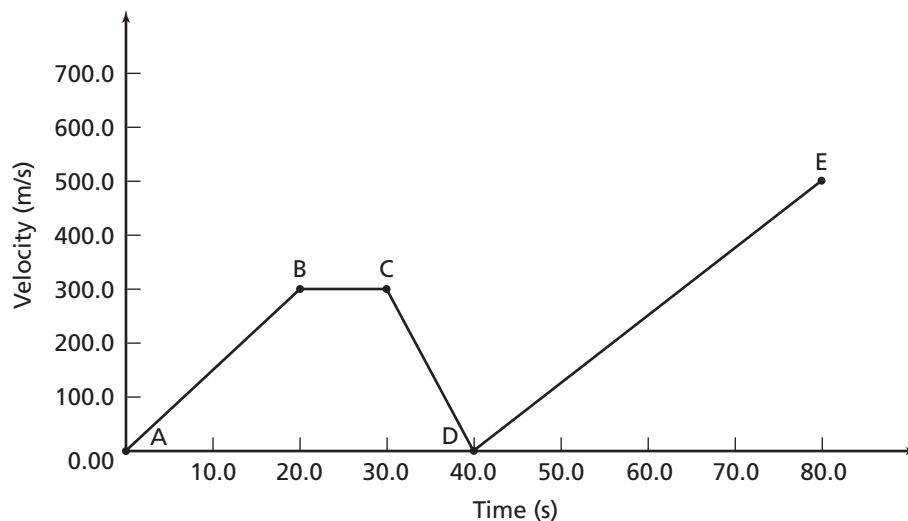

2. If you throw a ball straight upward, it will rise into the air and then fall back down toward the ground. Imagine that you throw the ball with an initial velocity of 13.7 m/s.
  - a. How long does it take the ball to reach the top of its motion?
  - b. How far will the ball rise before it begins to fall?
  - c. What is its average velocity during this period?
3. A car is traveling at 20 m/s when the driver sees a ball roll into the street. From the time the driver applies the brakes, it takes 2 s for the car to come to a stop.
  - a. What is the average acceleration of the car during that period?
  - b. How far does the car travel while the brakes are being applied?
4. A hot air balloon is rising at a constant speed of 1.00 m/s. The pilot accidentally drops his pen 10.0 s into the flight.
  - a. How far does the pen drop?
  - b. How fast is the pen traveling when it hits the ground, ignoring air resistance?

**3 Supplemental Problems***continued*

- 5.** A sudden gust of wind increases the velocity of a sailboat relative to the water surface from 3.0 m/s to 5.5 m/s over a period of 30.0 s.
- What is the average acceleration of the sailboat?
  - How far does the sailboat travel during the period of acceleration?
- 6.** During a serve, a tennis ball leaves a racket at 180 km/h after being accelerated for 80.0 ms.
- What is the average acceleration on the ball during the serve in  $\text{m/s}^2$ ?
  - How far does the ball move during the period of acceleration?
- 7.** The table below shows the velocity of a student walking down the hallway between classes.
- What is happening to the student's speed during  $t = 60.0$  s and  $t = 61.0$  s?
  - What is his acceleration between  $t = 10.0$  s and  $t = 20.0$  s?
  - What is his acceleration between  $t = 60.0$  s and  $t = 61.0$  s?
  - Assuming constant acceleration, how far did he walk during the first 5 s?
- | Time (s) | Velocity (m/s) |
|----------|----------------|
| 0.0      | 0.0            |
| 10.0     | 1.5            |
| 20.0     | 1.5            |
| 30.0     | 1.5            |
| 31.0     | 0.0            |
| 40.0     | 0.0            |
| 50.0     | 3.0            |
| 60.0     | 3.0            |
| 61.0     | 0.0            |
- 8.** Anna walks off the end of a 10.0-m diving platform.
- What is her acceleration in  $\text{m/s}^2$  toward the pool?
  - How long does it take her to reach the water?
  - What is her velocity when she reaches the water?
- 9.** A rocket used to lift a satellite into orbit undergoes a constant acceleration of  $6.25 \text{ m/s}^2$ . When the rocket reaches an altitude of 45 km above the surface of Earth, it is traveling at a velocity of 625 m/s. How long does it take for the rocket to reach this speed?
- 10.** On the surface of Mars, the acceleration due to gravity is 0.379 times as much as that on the surface of Earth. A robot on Mars pushes a rock over a 500.0-m cliff.
- How long does it take the rock to reach the ground below the cliff?
  - How fast is the rock traveling when it reaches the surface?
  - How long would it take the rock to fall the same distance on the surface of Earth?
- 11.** A sky diver jumps from an airplane 1000.0 m above the ground. He waits for 8.0 s and then opens his parachute. How far above the ground is the sky diver when he opens his parachute?
- 12.** A speeding car is traveling at 92.0 km/h toward a police car at rest, facing the same direction as the speeding car. If the police car begins accelerating when the speeding car is 250.0 m behind the police car, what must the police car's acceleration be in order for the police car to reach the speeding car's velocity at the moment the speeding car catches up? Assume that the speeding car does not slow down.

## CHAPTER

## 4

## Supplemental Problems

## Forces in One Dimension

- You and your bike have a combined mass of 80 kg. How much braking force has to be applied to slow you from a velocity of 5 m/s to a complete stop in 2 s?
- Before opening his parachute, a sky diver with a mass of 90.0 kg experiences an upward force from air resistance of 150 N.
  - What net force is acting on the sky diver?
  - What is the sky diver's acceleration?
- A large helicopter is used to lift a heat pump to the roof of a new building. The mass of the helicopter is  $5.0 \times 10^3$  kg and the mass of the heat pump is 1500 kg.
  - How much force must the air exert on the helicopter to lift the heat pump with an acceleration of  $1.5 \text{ m/s}^2$ ?
  - Two chains connected to the load each can withstand a tension of 15,000 N. Can the load be safely lifted at  $1.5 \text{ m/s}^2$ ?
- In a lab experiment, you attach a 2.0-kg weight to a spring scale. You lift the scale and weight with a constant reading of 22.5 N.
  - What is the value and direction of the acceleration on the weight?
  - How far do you lift the weight in the first 2.0-s interval?
- As a large jet flies at a constant altitude, its engines produce a forward thrust of  $8.4 \times 10^5$  N. The mass of the plane is  $2.6 \times 10^5$  kg.
  - What is the forward acceleration of the plane, ignoring air resistance?
  - How much upward force must the air exert on the plane when it is flying horizontally?

- Two masses are tied to a rope on a pulley, as shown below.
  - When the system is released from this position, what is the acceleration of the 2.0-kg mass?
  - How long does it take for the 2.0-kg mass to fall to the floor?

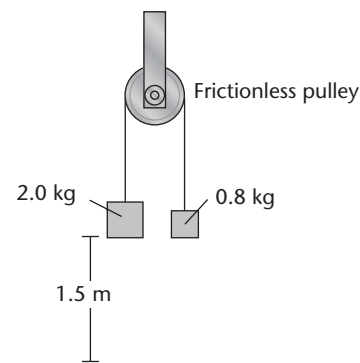

- A man is standing on a scale inside an airplane. When the airplane is traveling horizontally (in other words, the vertical acceleration of the plane is zero) the scale reads 705.6 N. What is the vertical acceleration of the plane in each of the following situations?
  - When the scale reads 950.0 N
  - When the scale reads 500.0 N
- An airboat glides across the surface of the water on a cushion of air. Perform the following calculations for a boat in which the mass of the boat and passengers is 450 kg.
  - If there is no friction, how much force must the propeller fan exert on the air to accelerate the boat at  $5.0 \text{ m/s}^2$ ?
  - If the actual acceleration with the fan generating the force calculated in part a is only  $4.95 \text{ m/s}^2$ , how much friction does the air cushion exert on the boat?
  - What is the upward force exerted by the air cushion on the boat?

**4 Supplemental Problems***continued*

- 9.** A golf ball with a mass of 45 g is struck by a club, leaving the tee with a speed of  $1.8 \times 10^2$  km/h. The period of acceleration was 0.50 m/s.
- What is the average acceleration on the ball as it was struck (in  $\text{m/s}^2$ )?
  - What is the force exerted on the club?
  - What is the force exerted on the club by the ball?
- 10.** A package of instruments is attached to a helium-filled weather balloon that exerts an upward force of 45 N.
- If the instrument package weighs 10.0 kg, will the balloon be able to lift it?
  - What is the upward acceleration if the instruments weigh 2.0 kg?
- 11.** A 12-kg block sits on a table. A 10.0-kg block sits on top of the 12-kg block. If there is nothing on top of the 10.0-kg block, what is the force that the table exerts on the 12-kg block?
- 12.** A box experiences a net force of 41 N while it is being lifted. What is the acceleration of the box?
- 13.** A rope can withstand  $1.000 \times 10^3$  N of tension. If the rope is being used to pull a 10.0-kg package across a frictionless surface, what is the greatest acceleration that will not break the rope?
- 14.** A 0.100-kg weight is attached to a spring scale. Find the reading on the scale for each of the following situations.
- When the scale is not moving
  - When the scale accelerates at  $2.4 \text{ m/s}^2$  in the horizontal direction
- 15.** A penny is dropped from the top of a 30.0-m-tall tower. The tower, however, is not located on Earth. The penny has a mass of 2.5 g and experiences a gravitational force of 0.028 N.
- What is acceleration due to gravity on this planet?
  - After 1.00 s, the penny has a velocity of 10.1 m/s. Assuming the force exerted on the penny by air resistance is uniform and independent of speed, what is the magnitude of the force of air resistance on the penny?
- 16.** The combined mass of a sled and its rider is 46.4 kg. The sled is pulled across a frozen lake so that the force of friction between the sled and the ice is very small.
- Assuming that friction between the sled and the ice is negligible, what force is required to accelerate the sled at  $3.45 \text{ m/s}^2$ ?
  - A force of 150.0 N is applied to the sled and produces an acceleration of  $3.00 \text{ m/s}^2$ . What is the magnitude of the force of friction that resists the acceleration?

CHAPTER

5

Supplemental Problems

Forces in Two Dimensions

1. A small plane takes off and flies 12.0 km in a direction southeast of the airport. At this point, following the instructions of an air traffic controller, the plane turns  $20.0^\circ$  to the east of its original flight path and flies 21.0 km. What is the magnitude of the plane's resultant displacement from the airport?

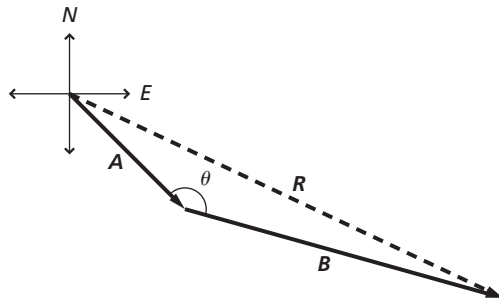

2. A hammer slides down a roof that makes a  $32.0^\circ$  angle with the horizontal. What are the magnitudes of the components of the hammer's velocity at the edge of the roof if it is moving at a speed of 6.25 m/s?

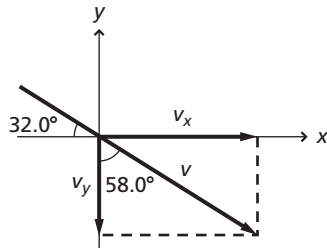

3. A worker has to move a 17.0-kg crate along a flat floor in a warehouse. The coefficient of kinetic friction between the crate and the floor is 0.214. The worker pulls horizontally on a rope attached to the crate, with a 49.0-N force. What is the resultant acceleration of the crate?

4. To get a cart to move, two farmers pull on ropes attached to the cart, as shown below. One farmer pulls with a force of 50.0 N in a direction  $35.0^\circ$  east of north, while the other exerts a force of 30.0 N in a direction  $25.0^\circ$  west of north. What are the magnitude and the direction of the combined force exerted on the cart?

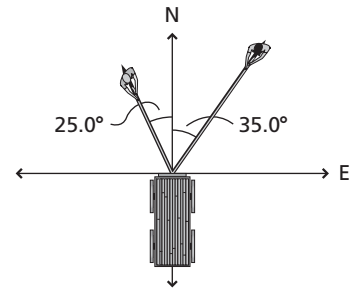

5. Takashi trains for a race by rowing his canoe on a lake. He starts by rowing along a straight path. Then he turns and rows 260.0 m west. If he then finds he is located 360.0 m exactly north of his starting point, what was his displacement along the straight path?

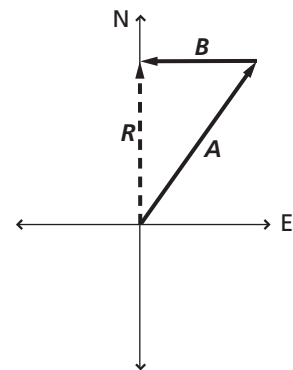

6. Mira received a 235-N sled for her birthday. She takes the sled out to a flat snowy field. When she pushes it with a 45.0-N horizontal force, it slides along at a constant speed. What is the coefficient of kinetic friction between the sled and the snow?

# 5 Supplemental Problems

continued

7. A rod supports a 2.35-kg lamp, as shown below.
- What is the magnitude of the tension in the rod?
  - Calculate the components of the force that the bracket exerts on the rod.

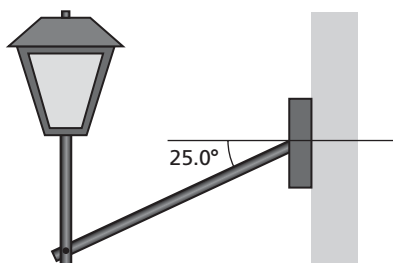

8. A 25.0-kg crate has an adjustable handle so that it can be pushed or pulled by the handle at various angles. Determine the acceleration of the crate for each situation shown in the diagram, given that the coefficient of sliding friction between the floor and the bottom of the crate is 0.20.

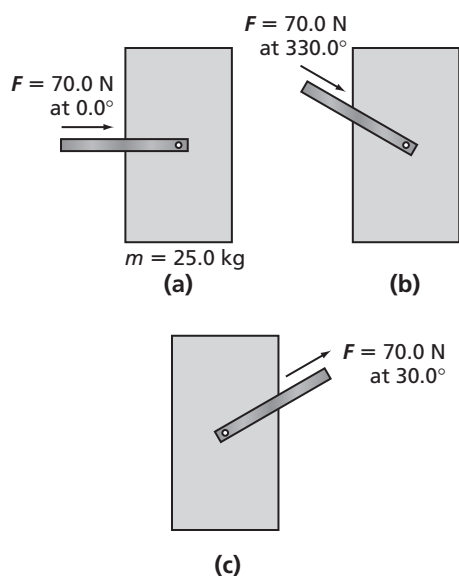

9. A child shoves a small toboggan weighing 100.0 N up a snowy hill, giving the toboggan an initial speed of 6.0 m/s. If the hill is inclined at an angle of  $32^\circ$  above the horizontal, how far along the hill will the toboggan slide? Assume that the coefficient of sliding friction between the toboggan and the snow is 0.15.
10. Two objects are connected by a string passing over a frictionless, massless pulley. As shown below, the block is on an inclined plane and the ball is hanging over the top edge of the plane. The block has a mass of 60.0 kg, and the coefficient of kinetic friction between the block and the inclined plane is 0.22. If the block moves at a constant speed down the incline, and the ball rises at a constant speed, what is the mass of the hanging ball?

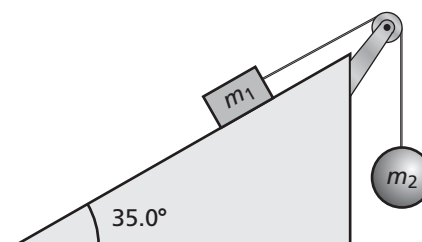

## CHAPTER

## 6

## Supplemental Problems

## Motion in Two Dimensions

- A busy waitress slides a plate of apple pie along a counter to a hungry customer sitting near the end of the counter. The customer is not paying attention, and the plate slides off the counter horizontally at  $0.84 \text{ m/s}$ . The counter is  $1.38 \text{ m}$  high.
  - How long does it take the plate to fall to the floor?
  - How far from the base of the counter does the plate hit the floor?
  - What are the horizontal and vertical components of the plate's velocity just before it hits the floor?
- DuWayne is on his way out to go grocery shopping when he realizes that he has left his wallet at home. He calls his wife, Yolanda, who opens a high window and throws DuWayne's wallet down at an angle  $23^\circ$  below the horizontal. Yolanda throws the wallet at a speed of  $4.2 \text{ m/s}$ , and the wallet leaves her hand at a height  $2.0 \text{ m}$  above the ground. How far from the base of the house does the wallet reach the ground?
- A skateboarder is slowing down at a rate of  $0.70 \text{ m/s}^2$ . At the moment he is moving forward at  $1.5 \text{ m/s}$ , he throws a basketball upward so that it reaches a height of  $3.0 \text{ m}$ , and then he catches it at the same level it was thrown without changing his position on the skateboard. Determine the vertical and horizontal components of the ball's velocity relative to the skateboard when the ball left his hand.
- A tennis ball is thrown toward a vertical wall with a speed of  $21.0 \text{ m/s}$  at an angle of  $40.0^\circ$  above the horizontal. The horizontal distance between the wall and the point where the tennis ball is released is  $23.0 \text{ m}$ .
  - At what height above the point of release does the tennis ball hit the wall?
  - Has the tennis ball already passed the highest point on its trajectory when it hits the wall? Justify your answer.
- The Moon revolves around Earth in a circular orbit with a radius of  $3.84 \times 10^8 \text{ m}$ . It takes  $27.3$  days for the Moon to complete one orbit around Earth. What is the centripetal acceleration of the Moon?
- A clown rides a small car at a speed of  $15 \text{ km/h}$  along a circular path with a radius of  $3.5 \text{ m}$ .
  - What is the magnitude of the centripetal force on a  $0.18\text{-kg}$  ball held by the clown?
  - At the point where the car is headed due north, the clown throws the ball vertically upward with a speed of  $5.0 \text{ m/s}$  relative to the moving car. To where must a second clown run to catch the ball the same distance above the ground as it was thrown?
- A  $0.45\text{-kg}$  ball is attached to the end of a cord of length  $1.4 \text{ m}$ . The ball is whirled in a circular path in a horizontal plane. The cord can withstand a maximum tension of  $57.0 \text{ N}$  before it breaks. What is the maximum speed the ball can have without the cord breaking?
- The moving sidewalk at an airport has a speed of  $0.9 \text{ m/s}$  toward the departure gate.
  - A man is walking toward the departure gate on the moving sidewalk at a speed of  $1.0 \text{ m/s}$  relative to the sidewalk. What is the velocity of the man relative to a woman who is standing off the moving sidewalk?

**6 Supplemental Problems***continued*

- b.** On a similar moving sidewalk that is going in the opposite direction, a child walks toward the terminal at a speed of 0.4 m/s relative to the sidewalk. What is the velocity of the man relative to the child?
- 9.** On a sightseeing trip in Europe, Soraya is riding in a tour bus moving north along a straight section of road at 8.0 m/s. While Soraya looks out at a forest, she hears some passengers on the other side of the bus say they can see a famous castle from their side. Soraya hurries straight across the bus, going east at 4.0 m/s relative to the bus, so that she can also see the castle. What is Soraya's velocity relative to the castle?
- 10.** A kite is tethered to a stake on a beach. The wind has a constant velocity of 16 km/h at an angle of  $15^\circ$  from the horizontal relative to the beach. Find the components of the kite's velocity relative to the wind.
- 11.** A marble rolls off the edge of a table that is 0.734 m high. The marble is moving at a speed of 0.122 m/s at the moment that it leaves the edge of the table. How far from the table does the marble land?
- 12.** Frank and Carmen are playing catch with a flying disk when it gets stuck in a tree. The disk is lodged between two branches 8.8 m above the ground. If a rock is thrown straight up to hit the disk, what is the minimum speed with which the disk must be thrown?
- 13.** A baseball player is playing catch with his friend. When the ball leaves his hand it is moving at 29.1 m/s. He throws the ball at an angle of  $30.0^\circ$  above the horizontal. His friend catches the ball at the same height from which it was thrown. How far is the baseball player from his friend?
- 14.** A car moving at 12.67 m/s rounds a bend in the road. The bend is semicircular and has a radius of 60.0 m. What is the centripetal acceleration of the car?
- 15.** A town has a large clock on the hall in the town square. The clock has hands that show the hours, minutes, and seconds. A fly is sitting on the tip of the hand that shows the seconds. If the length of the hand is 1.20 m, what is the fly's centripetal acceleration?
- 16.** A rock is tied to a string and spun in a horizontal circle. The string is 1.8 m long and the rock has an acceleration of  $3.4 \text{ m/s}^2$ . What is the tangential velocity of the rock?
- 17.** An airplane flies north at 300.0 km/h relative to the air and the wind is blowing south at 15.0 km/h. What is the airplane's velocity relative to the ground?



## CHAPTER

## 7

## Supplemental Problems

## Gravitation

- Titan, the largest moon of Saturn, has a mean orbital radius of  $1.22 \times 10^9$  m. The orbital period of Titan is 15.95 days. Hyperion, another moon of Saturn, orbits at a mean radius of  $1.48 \times 10^9$  m. Use Kepler's third law of planetary motion to predict the orbital period of Hyperion in days.
- The mass of Earth is  $5.97 \times 10^{24}$  kg, the mass of the Moon is  $7.35 \times 10^{22}$  kg, and the mean distance of the Moon from the center of Earth is  $3.84 \times 10^5$  km. Use these data to calculate the magnitude of the gravitational force exerted by Earth on the Moon.
- Two identical bowling balls are placed 1.00 m apart. The gravitational force between the bowling balls is  $3.084 \times 10^{-9}$  N.
  - Find the mass of a bowling ball.
  - Compare the weight of the first ball with the gravitational force exerted on it by the second ball.
- The planet Mercury travels around the Sun with a mean orbital radius of  $5.8 \times 10^{10}$  m. The mass of the Sun is  $1.99 \times 10^{30}$  kg. Use Newton's version of Kepler's third law to determine how long it takes Mercury to orbit the Sun. Give your answer in Earth days.
- Io, the closest moon to Jupiter, has a period of 1.77 days and a mean orbital radius of  $4.22 \times 10^8$  m. Use this information together with Newton's version of Kepler's third law to determine the mass of Jupiter.
- A satellite is placed in a circular orbit 100.0 km above Earth's surface. Earth's mass is  $5.97 \times 10^{24}$  kg and its average radius is  $6.38 \times 10^6$  m.
  - What is the speed of the satellite?
  - How many minutes does it take the satellite to complete one orbit?
- You have been hired to do calculations for a consortium that plans to place a space station in orbit around Mars. The mass of Mars is  $6.42 \times 10^{23}$  kg and its radius is  $3.40 \times 10^6$  m. In order for the space station to appear to remain over the same spot on Mars at all times, its orbital period must be equal to the length of a day on Mars:  $8.86 \times 10^4$  s. At what height above the surface of Mars should the space station be located in order to maintain this orbit? Use Newton's version of Kepler's third law.
- The asteroid Vesta has a mass of  $3.0 \times 10^{20}$  kg and an average radius of 510 km.
  - What is the acceleration due to gravity at its surface?
  - How much would a 95-kg astronaut weigh at the surface of Vesta?
- The Moon has an average radius of  $1.74 \times 10^3$  km. At the Moon's surface,  $g_{\text{Moon}}$  has a value of  $1.62 \text{ m/s}^2$ . What is the value of the acceleration due to gravity at an altitude of  $1.00 \times 10^2$  km above the Moon's surface?
- Use data from Table 7-1 in your textbook.
  - Find the Sun's gravitational field strength at Earth's orbit.
  - How does this compare with the Sun's gravitational field strength at the orbit of Pluto?
- Earth has an orbital period of 365 days and its mean distance from the Sun is  $1.495 \times 10^8$  km. The planet Pluto's mean distance from the Sun is  $5.896 \times 10^9$  km. Using Kepler's third law, calculate Pluto's orbital period in Earth days.

**7 Supplemental Problems***continued*

- 12.** The mass of Earth is  $5.98 \times 10^{24}$  kg and the mass of the Sun is 330,000 times greater than the mass of Earth. If the center of Earth is, on average,  $1.495 \times 10^{11}$  m from the center of the Sun, calculate the magnitude of the gravitational force the Sun exerts on Earth.
- 13.** Two metal spheres, each weighing 24.0 kg are placed 0.0500 m apart. Calculate the magnitude of the gravitational force the two spheres exert on each other.
- 14.** A car and a truck are traveling side by side on the highway. The car has a mass of  $1.37 \times 10^3$  kg and the truck has a mass of  $9.92 \times 10^3$  kg. If the cars are separated by 2.10 m, find the force of gravitational attraction between the car and the truck.
- 15.** A satellite is in orbit  $3.11 \times 10^6$  m from the center of Earth. The mass of Earth is  $5.98 \times 10^{24}$  kg. Calculate the orbital period of the satellite.
- 16.** The planet Venus orbits the Sun with a mean orbital radius of  $1.076 \times 10^{11}$  m. The mass of the Sun is  $1.99 \times 10^{30}$  kg. Using Newton's version of Kepler's third law, calculate the orbital period of Venus.
- 17.** A satellite is in orbit at a distance of 6750 km from the center of Earth. The mass of Earth is  $5.98 \times 10^{24}$  kg. What is the orbital speed of the satellite?
- 18.** Given that the mass of Earth is  $5.98 \times 10^{24}$  kg, what is the orbital radius of a satellite that has an orbital period of exactly one day (assume that a day is exactly 24 hours in length)?
- 19.** The Moon has a mass of  $7.349 \times 10^{22}$  kg and a radius of 1737 km. How much would a 75.0-kg person weigh standing on the surface of the Moon?
- 20.** Jupiter has a mass of  $1.90 \times 10^{27}$  kg and a radius of  $7.145 \times 10^4$  km. Earth has a mass of  $5.98 \times 10^{24}$  kg and a radius of  $6.38 \times 10^6$  m. How many times their Earth weight would a 75.0-kg person weigh when standing on the surface of Jupiter? (Assume Jupiter has a solid surface to stand on.)
- 21.** A 5.0-kg mass weighs 8.1 N on the surface of the Moon. If the radius of the Moon is 1737 km, what is the mass of the Moon?
- 22.** Acceleration due to gravity on Earth's surface is  $9.80 \text{ m/s}^2$ . Thus, a 1.00-kg mass weighs 9.80 N on the surface of Earth. If the radius of Earth was cut exactly in half but the mass of Earth remained unchanged, how much would a 1.00-kg mass weigh on the surface of Earth?

CHAPTER

# 8 Supplemental Problems

## Rotational Motion

- Jupiter, the largest planet in our solar system, rotates around its own axis in 9.84 h. The diameter of Jupiter is  $1.43 \times 10^8$  m.
  - What is the angular speed of Jupiter's rotation in rad/s?
  - What is the linear speed of a point on Jupiter's equator, due to Jupiter's rotation?
- A computer disk drive optimizes the data transfer rate by rotating the disk at a constant angular speed of 34.1 rad/s while it is being read. When the computer is searching for one of your files, the disk spins for 0.892 s.
  - What is the angular displacement of the disk during this time?
  - Through how many revolutions does the disk turn during this time?
- You are doing your laundry. When the washing machine goes into its spin cycle, the tub starts from an angular speed of 2.30 rad/s, then speeds up smoothly for 8.00 s, until it is turning at 5.00 rev/s. Calculate the angular acceleration of the tub during this time.
- One of the beaters of an electric mixer is shown below. What is the centripetal acceleration of the outer part of a blade as it rotates at a rate of 1200 rev/min?



- A tractor wheel has a radius of 0.84 m. How far does a point on the wheel's edge move when the wheel is rotated through an angle of  $67^\circ$ ?
- In order for a bolt to be tightened, a torque of 45.0 N·m is needed. You use a 0.341-m long wrench, and you exert a maximum force of 189 N at an angle as shown to the right. What is the smallest angle, with respect to the wrench, at which you can exert this force and still tighten the bolt?
- Chloe, whose mass is 56 kg, sits 1.2 m from the center of a seesaw. Josh, whose mass is 84 kg, wants to balance Chloe. Where on the seesaw should Josh sit?
- An athlete exercises using a dumbbell consisting of a long, thin, lightweight rod with a heavy sphere at each end, as shown below. The length of the rod is  $L = 0.78$  m, and the mass of each sphere is 22.0 kg. The mass of the rod can be neglected.

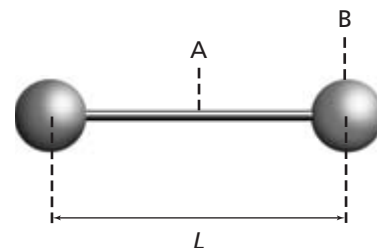
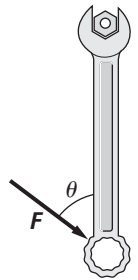

- Find the moment of inertia of the system for rotation about axis A, at the midpoint between the two spheres.
- Find the moment of inertia of the system for rotation about axis B, at one end of the rod.

# 8 Supplemental Problems

continued

9. A fisherman starts his outboard motor by pulling on a rope wrapped around the outer rim of a flywheel. The flywheel is a solid cylinder with a mass of 9.5 kg and a diameter of 15 cm. The flywheel starts from rest and after 12 s, it rotates at 51 rad/s.
- What torque does the fisherman apply to the flywheel?
  - How much force does the fisherman need to exert on the rope to apply this torque?
10. A 91.2-N ladder is in equilibrium, resting on two sawhorses, as shown below. What force does each sawhorse exert on the ladder?

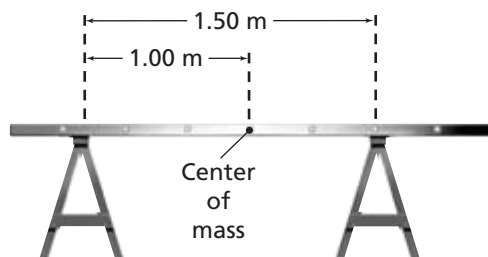

- The tire on an automobile is measured as completing 54 rotations in 8.0 s. What is the angular velocity of this rotating tire?
- A cyclist wants to complete 10 laps around a circular track 1.0 km in diameter in exactly 1 h. At what linear velocity must this cyclist ride?
- A carnival Ferris wheel takes 45.0 s to move from rest to the maximum ride speed. At its maximum speed, the ride makes one complete revolution every 12.0 s. Calculate the angular acceleration of this ride.
- A 75.0-g mass is attached to a 1.0-m length of string and whirled around in the air at a rate of 4.0 rev/s when the string breaks.
  - What was the breaking force of the string?
  - What was the linear velocity of the mass as soon as the string broke?
- A 2.0-g coin is placed on a flat turntable at a distance of 5.0 cm from the center of rotation. The turntable rotates at a rate of 1.0 rev/s and the coin rides without slipping.
  - What is the linear speed of the coin?
  - What is the centripetal acceleration of the coin?
  - What is the frictional force keeping the coin from slipping?
- A grocer wants to measure out exactly 500.0 g of rice using an old balance scale. The quantity of rice is placed on a pad 4.5 cm from the pivot point and small metal weights are placed on the opposite end 28.0 cm from the pivot point until the scale balances. How much weight should the grocer use to measure out the necessary quantity of rice?
- You have an irregular flat object mounted on a table so it can rotate freely about a central axis. You observe that if you apply a perpendicular force of 5.5 N at a distance of 24.0 cm from the axis of rotation, you can accelerate the object from rest to 3.0 rev/s in just 1.0 s. What is the moment of inertia for this irregular object?
- A wagon wheel that is 1.60 m in diameter is mounted vertically so it can turn freely. You grab one of the spokes of the wheel near the outer rim and pull down with 25 N of force. The spoke that you grip on the wheel makes an angle of  $40.0^\circ$  with the horizontal before you apply the force.
  - How much torque do you apply to the wheel? Assume that the rim thickness is negligible so that you are applying the force 0.80 m from the center of the wheel.
  - If this wheel has a mass of 15 kg, what is its moment of inertia? Disregard the mass of the spokes.
  - What is the angular acceleration of this wheel as you turn it?

## CHAPTER

## 9

## Supplemental Problems

## Momentum and Its Conservation

- A golfer uses a club to hit a 45-g golf ball resting on an elevated tee so that the golf ball leaves the tee at a horizontal speed of +38 m/s.
  - What is the impulse on the golf ball?
  - What is the average force that the club exerts on the golf ball if they are in contact for  $2.0 \times 10^{-3}$  s?
  - What average force does the golf ball exert on the club during this time interval?
- A 0.0420-kg hollow racquetball with an initial speed of 12.0 m/s collides with a backboard. It rebounds with a speed of 6.0 m/s.
  - Calculate the total impulse on the ball.
  - If the contact time lasts for 0.040 s, calculate the average force on the ball.
- After dropping from a height of 1.50 m onto a concrete floor, a 50.0-g ball rebounds to a height of 0.90 m.
  - Find the impulse acting on the ball as it dropped.
  - Find the impulse acting on the ball as it rebounds.
  - Find the impulse on the ball while it was in contact with the floor.
- A tennis player receives a shot with the 60.0-g ball traveling horizontally at  $-50.0$  m/s, and returns the shot with the ball traveling horizontally. The tennis ball and the tennis racket are in contact for  $1.00 \times 10^{-3}$  s. The average force exerted on the ball by the tennis racket is  $5.70 \times 10^3$  N. Find the speed of the tennis ball after it leaves the racket.
- A 180-kg crate is sitting on the flatbed of a moving truck. The coefficient of sliding friction between the crate and the truck bed is 0.30. Two taut cables are attached to the crate, one on each side. Each cable can exert a maximum horizontal force of 650 N either forward or backward if the crate begins to slide. If the truck stops in 1.8 s, what is the maximum speed the truck could have been moving without breaking the cables?
- A single uranium atom has a mass of  $3.97 \times 10^{-25}$  kg. It decays into the nucleus of a thorium atom by emitting an alpha particle at a speed of  $2.10 \times 10^7$  m/s. The mass of an alpha particle is  $6.68 \times 10^{-27}$  kg. What is the recoil speed of the thorium nucleus?
- A 10.0-g bullet is fired into a stationary 5.00-kg block of wood. The bullet lodges inside the block. The speed of the block-plus-bullet system immediately after the collision is measured as 0.600 m/s. What was the original speed of the bullet?
- Aisha is sitting on frictionless ice and holding two heavy ski boots. Aisha weighs 637 N, and each boot has a mass of 4.50 kg. Aisha throws both boots forward at the same time, at a velocity of 6.00 m/s relative to her. What is Aisha's resulting velocity?

# 9 Supplemental Problems

continued

- 9.** Two cars enter an icy intersection. A blue car with a mass of  $2.50 \times 10^3$  kg is heading east at 20.0 m/s, and a red car with a mass of  $1.45 \times 10^3$  kg is going north at 30.0 m/s. The two vehicles collide and stick together. Determine the speed and direction of the cars as they skid away together just after colliding.
- 10.** A 2.00-kg puck moving to the right at a velocity of 6.00 m/s at an angle of  $45.0^\circ$  below the horizontal collides at point A with a 1.00-kg puck traveling to the right at a velocity of 3.00 m/s at an angle of  $45.0^\circ$  above the horizontal, as shown below. After the collision, the 2.0-kg puck moves toward the right at a velocity of 4.50 m/s at an angle of  $25.0^\circ$  below the horizontal. What is the velocity of the 1.0-kg puck immediately after the collision?

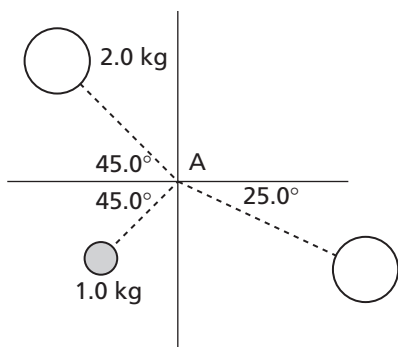

- 11.** At 9.0 s after takeoff, a 250-kg rocket attains a vertical velocity of 120 m/s.
- What is the impulse on the rocket?
  - What is the average force on the rocket?
  - What is its altitude?
- 12.** In a circus act, a 18-kg dog is trained to jump onto a 3.0-kg skateboard moving with a velocity of 0.14 m/s. At what velocity does the dog jump onto the skateboard if afterward the velocity of the dog and skateboard is  $-0.10$  m/s?
- 13.** While sitting in a stationary wagon, a girl catches a 2.6-kg medicine ball moving at a speed of 2.7 m/s.
- If the 11-kg wagon is on frictionless wheels, what is the velocity of the girl, wagon, and ball after she has caught the ball? The girl's mass is 55 kg. Ignore friction between the wheels and the road.
  - The girl then throws the ball back at a speed of 2.7 m/s relative to the wagon. What is the velocity of the girl and the wagon right after she has thrown the ball?
- 14.** A collision between two identical pucks, one moving and the other stationary, takes place on ice. The puck with an initial momentum of  $4.0$  kg·m/s is deflected  $60.0^\circ$  eastward from its original path. Using the law of conservation of momentum, what is the momentum of the puck that was originally stationary after the collision?

## CHAPTER

## 10

## Supplemental Problems

## Energy, Work, and Simple Machines

- A player pushes a 250-g hockey puck over frictionless ice with a constant force, causing it to accelerate at  $24 \text{ m/s}^2$  over a distance of 50.0 cm.
  - Find the work done by the hockey player on the puck.
  - What is the change in the kinetic energy of the puck?
- You exert a horizontal force of 4.6 N on a textbook as you slide it 0.60 m across a library table to a friend.
  - Calculate the work you do on the book.
  - Your friend returns the book by pushing it with a force of 6.2 N at an angle of  $30.0^\circ$  below the horizontal. What is the work done by your friend on the book?
- Shown below is a graph of force versus displacement for an object being pulled. Determine the work done by the force in pulling the object 7.0 m.

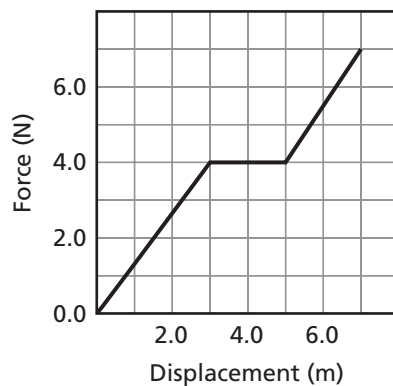

- A ski lift carries a 75.0-kg skier at 3.00 m/s for 1.50 min along a cable that is inclined at an angle of  $40.0^\circ$  above the horizontal.
  - How much work is done by the ski lift?
  - How much power is expended by the ski lift?
- An electric motor lifts an elevator at a constant speed of 54.0 km/h. The engine must exert a force of 9.00 kN in order to balance the weight of the elevator and the friction in the elevator cable. What power does the motor produce in kW?
- Leah is helping to build a water habitat in a neighborhood park. The habitat includes an upper pond connected to a lower pond, 3.2 m below, by a trickling stream with several small cascades. At a home-building store, she finds a 45-W pump that has a maximum circulation rate of 1900 L of water per hour. Can the pump develop enough power to raise the water from the lower to the upper pond? (The mass density of water,  $\rho$ , is 1.00 kg/L.)
- Ali uses a pulley system to raise a 30.0-kg carton a vertical distance of 15.3 m. He exerts a force of 211 N and pulls the rope 28.0 m.
  - What is the *MA* of this pulley system?
  - What is the efficiency of the system?
- Using a block-and-tackle, a mover takes up 18.5 m of rope to raise a 115-kg stove from the ground to a window ledge 3.7 m high. What force must he exert on the rope if the efficiency of the block-and-tackle is 63 percent?
- Rohit lifts a 89-kg crate by exerting a force of 120 N on a lever, through a distance of 1.6 m. The efficiency of the lever is 92 percent. How far is the crate lifted?

# 10 Supplemental Problems

continued

- 10.** While unpacking a blind, Rahul sees that the shaft of the blind, which rotates the horizontal slats, is connected to a small gearbox. The gearbox also is connected to the wand, which is turned to open and close the slats, as shown below. Rahul measures the wand's diameter as 1.00 cm and the shaft's diameter as 1.25 cm. He notices that to rotate the slats  $180^\circ$ , the wand has to make three complete rotations. What ratio of gear teeth does the gearbox contain?

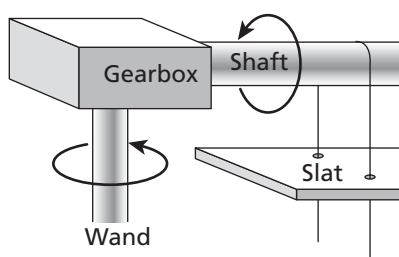

- 11.** A gardener lifts a 25-kg bag of sand to a height of 1.1 m, carries it across the yard a distance of 15 m and sets it down against the wall.
- How much work does the gardener do when he lifts the bag of sand?
  - How much total work is done after the gardener sets down the bag of sand?
- 12.** A 0.300-kg baseball is thrown at a speed of 6.5 m/s. The batter hits the ball and it flies into the outfield at a speed of 19.2 m/s. How much work is done in hitting the baseball?
- 13.** A worker pushes a lawn mower with a force of 23.0 N, exerted along the direction of the handle and at a speed of 1.25 m/s across a lawn that is 18.5 m wide. The handle of the lawn mower makes an angle of  $60.0^\circ$  with the horizontal.
- How much work is done by the worker?
  - If the worker is pushing as hard as possible, how else can the amount of work done be increased?
  - How much power is exerted by the worker?
- 14.** Hoover Dam has a capacity for producing  $2.0 \times 10^6$  kW of power. How much work is done by the turbines each day?
- 15.** Calculate the efficiency of a pulley system when an effort of 200 N of force acting through 10 m lifts a mass of 90 kg a distance of 2.0 m.
- 16.** A particular lever-and-fulcrum system provides a mechanical advantage of 3.5.
- If you are able to exert  $4.0 \times 10^2$  N of force, what is the largest mass you could lift with this lever system?
  - Even though this lever system increases the force you are able to exert, it can only lift an object a distance of 5.0 cm even though you move the lever through a distance of 80.0 cm. What is the efficiency of this lever system?
- 17.** The efficiency of an inclined plane is 75 percent. If the length of the plane is 8.0 m and its height is 1.5 m, what force acting parallel to the plane is required to move a 180-kg block up the plane? (Neglect friction.)



## CHAPTER

# 11 Supplemental Problems

## Conservation of Energy

- Natasha weighs 530 N. What is her kinetic energy as she swims at a constant speed, covering a distance of 72 m in 1.0 min?
- A 6.00-g block initially at rest is pulled to the right along a frictionless horizontal surface by a constant horizontal force of  $1.20 \times 10^{-2}$  N for a distance of 3.00 cm.
  - What is the work done by the force?
  - What is the change in the kinetic energy of the block?
  - What is the speed of the block after the force is removed?
- Zeke slides down a snow hill on a rubber mat. Zeke's mass is 76.0 kg and the mass of the mat is 2.00 kg. Zeke starts from rest at the crest of the hill. Frictional forces may be disregarded.
  - What is the change in the gravitational potential energy of Zeke and the mat when they slide to 1.20 m below the crest?
  - What is the change in the kinetic energy of Zeke and the mat when they slide to 1.20 m below the crest?
  - How fast are Zeke and the mat moving when they are 1.20 m below the crest?
- Rohit can consistently throw a 0.200-kg ball at a speed of 12.0 m/s. On one such throw, Rohit throws the ball straight upward and it passes the top of a flagpole when it is 6.00 m above the ball's initial position.
  - What is the ball's gravitational potential energy when it passes the top of the flagpole? (Assume the ball's initial gravitational energy is 0 J).
  - What is the ball's kinetic energy as it passes the top of the flagpole?
  - What is the ball's velocity as it first passes the top of the flagpole?
  - What is the maximum height to which the ball will rise?
- What is the change in gravitational potential energy when a  $7.0 \times 10^2$ -kg elevator moves from the second floor (6.0 m above the street) to the top floor (252.0 m above the street) of a building?
- In a hardware store, paint cans, which weigh 46.0 N each, are transported from storage to the back of the paint department by placing them on a ramp that is inclined at an angle of  $24.0^\circ$  above the horizontal. The cans slide down the ramp at a constant speed of 3.40 m/s and then slide onto a table made of the same material as the ramp. How far does each can slide on the table's horizontal surface before coming to rest?
- Meena releases her 10.5-kg toboggan from rest on a hill. The toboggan glides down the frictionless slope of the hill, and at the bottom of the slope it moves along a rough horizontal surface, which exerts a constant frictional force on the toboggan.
  - When the toboggan is released from a height of 15.0 m, it travels 6.0 m along the horizontal surface before coming to rest. How much work does the frictional force do on the toboggan?
  - From what height should the toboggan be released so that it stops after traveling 10.0 m on the horizontal surface?
- Kuan stands on the edge of a building's flat roof, 12 m above the ground, and throws a 147.0-g baseball straight down. The ball hits the ground at a speed of 18 m/s. What was the initial speed of the ball?

# 11 Supplemental Problems

continued

9. As shown below, a 450-kg roller-coaster car starts from rest at point A at a height of 47 m, rolls down the track, reaching point B at a speed of 25 m/s, and then rolls up a second hill where it reaches a height of 23 m before coming to rest (at point C). What are the gravitational potential energy and kinetic energy of the car when it is at points A, B, and C?

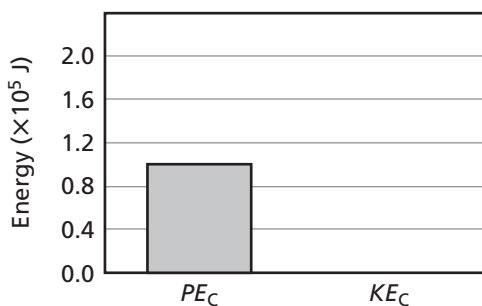
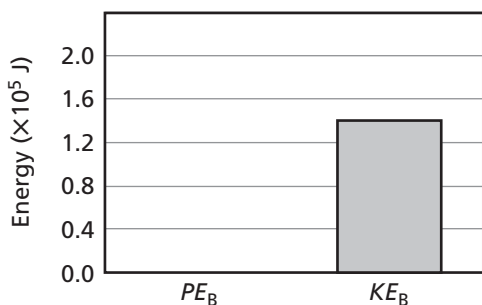
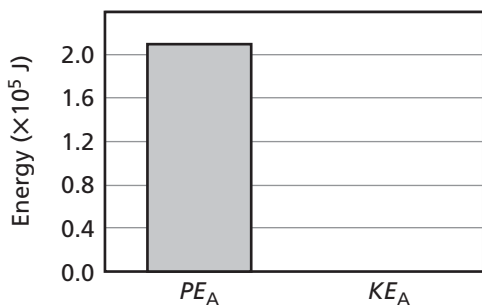
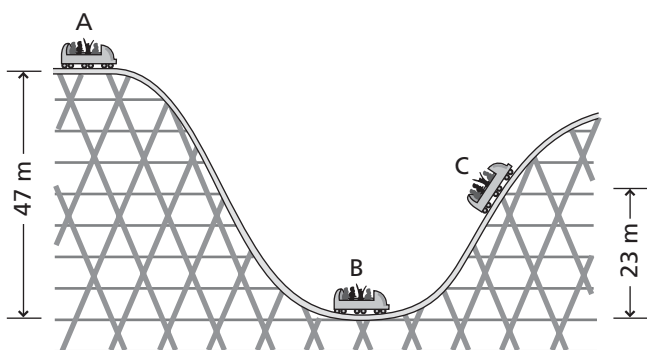

10. Erin holds the 1.20-kg bob of a pendulum at a level at which its gravitational potential energy is 3.00 J, and then releases it.
- Predict the speed of the bob as it passes through its lowest point on the swing.
  - Erin releases the bob from rest and uses a photogate to measure its speed as it passes through its lowest point. She finds that the actual speed is 93.2 percent of the predicted value. How much work did frictional forces do on the pendulum?
  - By what percentage was the pendulum's original energy decreased due to the work done by frictional forces on the pendulum as it moved from its release point to its lowest point?
11. A loaded freight car of mass  $50.0 \times 10^3$  kg, moving at 18.0 km/h along a straight, level track, collides with a stationary empty freight car of mass  $15.0 \times 10^3$  kg. At the collision, the two boxcars lock together.
- What is the velocity of the moving pair of boxcars after the collision?
  - How much energy is lost during the collision?
12. An arrow with a mass of 320 g is shot straight up into the air and reaches a height of 150 m before stopping and falling back to the ground.
- How much work is done by gravity as the arrow reaches its maximum height?
  - If the arrow's kinetic energy is zero at its maximum height, calculate the initial velocity of this arrow as it is shot from the ground.
13. The nucleus of a single atom of uranium U-235 consists of 92 protons and 143 neutrons. How much potential energy is contained within just a single uranium nucleus?

## CHAPTER

## 12

## Supplemental Problems

## Thermal Energy

- In order to cook pasta, 1.8 L of tap water must first be heated from 24°C to boiling at 100°C. If the density of water is 1.00 kg/L, how much heat must be added for the water to reach its boiling point?
- Some of the best pots and pans for cooking are made of copper. To learn why, compare copper pots to aluminum pots. Assume that  $5.00 \times 10^4$  kJ of heat is added to a copper pot and an aluminum pot. Each pot has a mass of 2.2 kg.
  - How much does the temperature of the copper pot increase?  
(specific heat = 385 J/kg·K)
  - How much does the temperature of the aluminum pot increase?  
(specific heat = 897 J/kg·K)
- There is 32.7 L of water in a bathtub. The temperature of the water is 42.1°C. If 11.3 L of water at 27.0°C is added to the bathtub, what is the new temperature of the bathwater?
- A 0.098-kg sample of methanol is heated from 34°C until it is completely vaporized. A total of 93.487 kJ is used. If the boiling point of methanol is 65°C, what is the heat of vaporization of methanol?
- A car engine releases  $5.6 \times 10^2$  kJ of energy as it cools. What is the change in temperature for each of the following potential coolants when it absorbs this amount of energy?
  - 2.6 kg of antifreeze (specific heat = 2380 J/kg·K)
  - 1.8 kg of methanol
  - 2.4 kg of water
- A calorimeter containing 1.2 kg of water at 23.0°C is used to find the specific heat of a number of substances. A 503-g sample of each substance is heated to 250°C and is placed in the calorimeter. For each of the following final temperatures, calculate the specific heat of the substance. Using the table at right, predict what each substance is.
  - 31.5°C
  - 32.8°C
  - 41.8°C
  - 28.2°C

Table 12-1			
Specific Heat of Common Substances			
Material	Specific Heat (J/kg·K)	Material	Specific Heat (J/kg·K)
Aluminum	897	Lead	130
Brass	376	Methanol	2450
Carbon	710	Silver	235
Copper	385	Steam	2020
Glass	840	Water	4180
Ice	2060	Zinc	388
Iron	450		

**12 Supplemental Problems***continued*

- 7.** A 935-kg car moving at 31 m/s comes to a stop. The brakes, which contain about 18 kg of iron, absorb all of the energy. By how much does the temperature of the brakes increase?
- 8.** A 23-g zinc block falling at 18 m/s strikes the ground and comes to a complete stop. All of the block's kinetic energy is converted into thermal energy and none of it leaves the block. By how much does the block's temperature increase?
- 9.** How much heat is required to completely vaporize a 23.0-kg block of ice at  $-8.00^{\circ}\text{C}$ ?
- 10.** A block of ice at  $-5.00^{\circ}\text{C}$  is added to a trough that contains 5.33 kg of water at  $34.0^{\circ}\text{C}$ . Assume that there is no heat loss to the surroundings. If all of the ice melts and the final temperature of the mixture is  $6.00^{\circ}\text{C}$ , what was the original mass of the ice?
- 11.** A patio is constructed from 360 2.6-kg bricks. What amount of energy is released from the patio as it cools  $6.0^{\circ}\text{C}$ ? The specific heat of brick is  $920\text{ J/kg}\cdot\text{K}$ .
- 12.** How much ice at  $0.0^{\circ}\text{C}$  will be melted by 1.0 g of steam condensing at  $100.0^{\circ}\text{C}$ ?
- 13.** The temperature of 150.0 g of zinc is lowered from  $25.0^{\circ}\text{C}$  to  $16.4^{\circ}\text{C}$  as 2.5 g of liquid nitrogen at its freezing point condenses on its surface. What is the heat of vaporization of nitrogen?
- 14.** The head of a jackhammer supplies mechanical energy to a 0.50-kg iron ingot at a rate of 950 W. If this mechanical energy were transferred to the ingot and converted to thermal energy with none transferred to the environment, what would be the temperature rise of the ingot in 2.0 s?
- 15.** While casting a silver ornament, a silversmith pours 0.12 kg of molten silver at  $1010^{\circ}\text{C}$  into a 2.40-kg iron mold at a temperature of  $35^{\circ}\text{C}$ . What will be the equilibrium temperature of the silver casting and mold? Use information in the following table, and assume no thermal energy is lost to the surrounding environment.

Table 12-2		
Material	Variable	Value
Iron	Heat of fusion	$2.66 \times 10^5\text{ J/kg}$
Iron	Melting point	$1535^{\circ}\text{C}$
Iron (s)	Specific heat	$450\text{ J/kg}\cdot^{\circ}\text{C}$
Silver	Heat of fusion	$1.04 \times 10^5\text{ J/kg}$
Silver (s)	Specific heat	$235\text{ J/kg}\cdot^{\circ}\text{C}$
Silver (l)	Specific heat	$290\text{ J/kg}\cdot^{\circ}\text{C}$
Silver	Melting point	$960^{\circ}\text{C}$

## CHAPTER

## 13

## Supplemental Problems

## States of Matter

1. A car with a mass of  $1.30 \times 10^3$  kg has  $0.127 \text{ m}^2$  of tire in contact with the road.
  - a. How much does the car weigh?
  - b. How much pressure does the car exert on the road?
  
2. A piston contains  $0.102 \text{ m}^3$  of gas at an initial pressure of 217 kPa and an initial temperature of  $23.0^\circ\text{C}$ . Use these as the starting conditions for the following questions.
  - a. What is the new pressure of the gas when the volume of the cylinder is reduced to  $0.074 \text{ m}^3$  while the temperature remains constant?
  - b. If the volume remains constant at  $0.102 \text{ m}^3$ , what will be the pressure of the gas at  $81^\circ\text{C}$ ?
  - c. What is the new pressure of the gas when the temperature is reduced to  $11^\circ\text{C}$  and the volume of the cylinder is increased to  $0.256 \text{ m}^3$ ?
  
3. A certain bicycle tire should be inflated to 250 kPa before it is used. If the tire is at 230 kPa when the air in the tire is at  $25^\circ\text{C}$ , what temperature does the air in the tire have to reach for the proper pressure in the tire to be attained? Assume that expansion of the tire itself is negligible.
  
4. A  $3.22 \times 10^{-5}\text{-m}^3$  glass tube filled with xenon is pressurized to 6.00 atm. The temperature of the gas is  $22.0^\circ\text{C}$ .
  - a. How many moles of gas are in the tube?
  - b. What is the mass of the gas in the tube? (Xenon has a molar mass of 131.29 g/mol.)
  
5. Two pistons are connected to a fluid-filled reservoir. The first piston has an area of  $3.002 \text{ cm}^2$ , and the second has an area of  $315 \text{ cm}^2$ .
  - a. If the first cylinder is pressed inward with a force of 50.0 N, what is the force that the fluid in the reservoir exerts on the second cylinder?
  - b. A third cylinder is connected to the reservoir. When the second cylinder is pressed inward with a force of 50 N, the fluid in the reservoir exerts a force of 135 N on the third cylinder. What is the area of the third cylinder?
  
6. A cube of stainless steel, 0.30 m on each side, is completely submerged in water.
  - a. What is the buoyant force on the cube?
  - b. What is the apparent weight of the cube? (The density of stainless steel is  $8.0 \times 10^3 \text{ kg/m}^3$ .)
  - c. What volume of steel would have to be removed from the center of the cube in order for the cube to float?
  
7. A wooden raft that measures  $1.20 \text{ m} \times 0.85 \text{ m} \times 0.10 \text{ m}$  has a mass of 9.77 kg. If the raft is to stay afloat in fresh water, what is the maximum amount of additional mass that can be added to the raft?
  
8. Free diving is a sport in which the contestants attempt to reach the greatest depth possible underwater without using supplemental oxygen. The world record for free diving is 85 m. What is the pressure of water at this depth?

**13 Supplemental Problems***continued*

- 9.** An aluminum ladder is 3.1 m long.
- How much does the ladder expand in length when its temperature rises from 13°C to 42°C?
  - By how much does the ladder's temperature rise if it expands 0.0304 m?
- 10.** What is the volume of 5.29 L of water at 9.0°C when it is heated to 99.0°C?
- 11.** Atmospheric pressure at sea level is measured as 101,325 Pa. What is the weight of the column of air above a 1-cm<sup>2</sup> patch of ground?
- 12.** A 100.0-L chamber contains an ideal gas at a temperature of 20.0°C and a pressure of 15 atm. One wall of the chamber moves as a piston and reduces the volume of the chamber to 75 L while raising the temperature to 27.0°C. What is the new pressure under these conditions?
- 13.** An ideal gas is trapped in a cylinder 1.0 m long and with a diameter of 12.5 cm. The pressure inside is measured as  $3.0 \times 10^5$  Pa with a temperature of 29°C. How many gas molecules are contained within this cylinder?
- 14.** What is the volume of 1 mol of an ideal gas under standard temperature and pressure of  $1.013 \times 10^5$  Pa and 0°C?
- 15.** A car with a mass of  $1.0 \times 10^3$  kg rests on a hydraulic lift that is 2.0 m wide and 10.0 m long. The lift is connected to a second cylindrical piston with only a 14.0-cm diameter and a hand pump. What force is necessary to lift the car off the ground using only the hand pump?
- 16.** A lake is 40.0 m deep. An air bubble with a volume of 18 cm<sup>3</sup> emerges from the bottom of the lake and rises to the surface.
- What is the pressure at the bottom of the lake?
  - What is the volume of the air bubble just before it reaches the surface? (Assume an ideal gas.)
- 17.** What fraction of an iceberg shows above the water? Use the density of ice as  $\rho_{\text{ice}} = 920 \text{ kg/m}^3$  and the density of sea water as  $\rho_{\text{water}} = 1030 \text{ kg/m}^3$ .
- 18.** The height of a cylindrical concrete support pillar for a bridge is 13.0 m during the winter when the air temperature averages 4°C.
- How much does the pillar grow during the summer when temperatures can reach 30°C?
  - The pillar is 1.5 m in diameter. How much does its volume increase during the summer?
  - Besides strength, why is concrete a better choice of materials for bridge support than aluminum?

## CHAPTER

## 14

## Supplemental Problems

## Vibrations and Waves

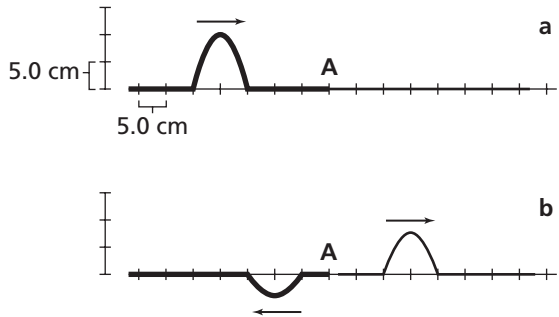
- A spring stretches by 25.0 cm when a 0.500-kg mass is suspended from its end.
  - Determine the spring constant.
  - How much elastic potential energy is stored in the spring when it is stretched this far?
- A spring has a spring constant of 135 N/m. How far must it be compressed so that 4.39 J of elastic potential energy is stored in the spring?
- On a planet where the gravitational acceleration is five times  $g$  on Earth, a pendulum swings back and forth with a period of 1.22 s. What is the length of the pendulum?
- Sonya hears water dripping from the eaves of the house onto a porch roof. She counts 30 drops in 1.0 min.
  - What is the frequency of the drops?
  - What is the period of the drops?
- Hiroshi is generating waves on a rope by flipping the rope up and down. Each motion up or down lasts 0.20 s. The distance from a crest to a trough is 0.40 m.
  - What is the amplitude of the wave?
  - What is the frequency of the waves?
- A water wave travels a distance of 15 m in 1 min. When this wave passes a point where a cork is floating in the water, it causes the cork to move up and down 12 times in 15 s.
  - What is the speed of this water wave?
  - What is the wavelength of this water wave?
  - What is the period of this water wave?
- A Love wave—one of the four types of waves associated with earthquakes—is a transverse wave in which the surface of Earth moves back and forth as the wave passes. What is the speed of a Love wave that has a period of 150 s and a wavelength of 620 km?
- A pulse with an amplitude of 0.53 m travels to the right along a rope. Another pulse, with an amplitude of  $-0.24$  m, travels to the left along the same rope. The two pulses approach each other. What is the amplitude of the rope at the point where the midpoints of the pulses pass each other?
- Part **a** of the figure below shows a pulse traveling at a speed of 1.0 m/s in a coil spring to which a second spring is attached at point A. Part **b** of the figure shows the springs a short time later.
 
  - What is the amplitude of the incident pulse?
  - What is the speed of the reflected pulse?
  - What is the speed of the transmitted pulse?

**14 Supplemental Problems***continued*

- 10.** A physics teacher attaches an electric oscillator to one end of a 2.0-m horizontal spring and attaches the other end of the spring to a stationary hook in the wall. She adjusts the frequency of the oscillator to produce a standing wave in the spring. Students observe that the standing wave has three nodes and two antinodes. She then doubles the frequency of the oscillations and produces another standing wave. How many nodes and antinodes do the students observe in the new standing wave?
- 11.** What magnitude force will compress a spring so that the spring elastic potential increases by 0.24 J? The spring constant is 18 N/cm.
- 12.** Each back-and-forth movement of the bob in a small pendulum clock releases a cog on a wheel. As the cog is released, the wheel undergoes a slight rotation. If the release of three cogs moves the second hand of the clock forward 1.0 s, what is the length of the pendulum?
- 13.** Calculate the frequency in hertz of each of the following:
- a.** a “new” moon (period = 27.3 days)
  - b.** a day on Earth
  - c.** a breath (Assume a breathing rate of 8–12 breaths in 60.0 s.)
  - d.** a heart beat (Assume a heart rate of 1.0–1.6 beats per second.)
- 14.** The distance between four consecutive antinodes of a standing wave in a spring is 42 cm. What is the wavelength of the standing wave? *Hint: The distance between two consecutive antinodes in a standing wave represents  $0.5 \lambda$ .*



## CHAPTER

## 15

## Supplemental Problems

## Sound

Assume that the speed of sound in air is 343 m/s, at 20°C, unless otherwise noted.

- The sound a mosquito makes is produced when it beats its wings at the average frequency of 620 wing beats per second. What is the wavelength of the sound waves produced by the mosquito?
- You are listening to an outdoor concert on a day when the temperature is 0°C. The sound of a wavelength of 0.490 m is emitted by a flute on the stage 125 m from where you are standing.
  - What is the time elapsed before you hear the sound emitted from the stage?
  - What is the frequency of the sound?
- The pulse-echo technique is used in diagnostic medical imaging. A short ultrasound pulse is emitted from the device, and echoes are produced when the pulse is reflected at a tissue interface. The echo signals are received back at the device and then analyzed to build up an image of the organ. The speed of sound in soft tissue is 1540 m/s. If an echo is received  $58.2 \times 10^{-6}$  s after the pulse was emitted, how far is the tissue interface from the ultrasound device?
- The engine of a jet plane taking off produces a sound level of 140 dB, and the sound wave has a pressure amplitude of 200 Pa. A baggage handler working next to a jet plane that is taking off is wearing specially designed hearing protectors that reduce the sound level entering his ear by 40 dB. What is the pressure amplitude of the sound waves entering his ear?
- While fishing from a boat anchored off-shore, you see another fishing boat between your boat and the shore. The other boat sounds a 510-Hz horn as it heads toward the shore at a speed of 18 m/s.
  - If your fishing boat is stationary, what is the frequency of the sound waves from the horn that reach you?
  - If your fishing boat now heads out to sea at a speed of 15 m/s, what is the frequency of the sound waves from the horn that reach you?
- A species of bat navigates by emitting short bursts of sound waves that have a frequency range that peaks at 58.0 kHz.
  - If a bat is flying at 4.0 m/s toward a stationary object, what is the frequency of the sound waves reaching the object?
  - What is the frequency of the reflected sound waves detected by the bat?
  - What is the difference between the frequency of the sound waves emitted by the bat and the frequency of the sound waves detected by the bat if the bat is flying at 4.0 m/s and the object is a moth approaching at 1.0 m/s?
- Hannah places an open, vertical glass tube into a container of water so that the lower end of the tube is submerged. She holds a vibrating tuning fork over the top of the tube while varying the water level in the tube. Hannah notices that the loudest sound is heard when the distance from the water to the top of the tube is 32.7 cm, and again when the distance is 98.2 cm. What is the frequency of the tuning fork?

**15 Supplemental Problems***continued*

- 8.** The six strings of a standard guitar are tuned to the following frequencies: 165, 220, 294, 392, 494, and 659 Hz.
- Find the lengths of the shortest open-ended organ pipes that would produce the same frequencies.
  - Sketch the pipes, showing their lengths to scale.
- 9.** The fundamental tone of an open-pipe resonator with a length of 48 cm is the same as the second harmonic tone of a closed-pipe resonator. What is the length of the closed-pipe resonator?
- 10.** You receive a CD with the following note: "The first sound on the CD is the sound of a 238-Hz tuning fork and a second tuning fork being struck simultaneously. The second sound on the CD is the sound of the second tuning fork and a 240.0-Hz tuning fork being struck simultaneously. What is the frequency of the second tuning fork?" Listening to the CD, you hear that the first sound has a beat frequency of 3.00 Hz and the second sound has a beat frequency of 5.00 Hz. Answer the question found in the note.
- 11.** A radio station broadcasts their signal with a wavelength of  $3.5 \mu\text{m}$ . Although your radio will translate this signal into audible sound, explain why you cannot hear the radio signal directly.
- 12.** Antennas are designed to be as long as the wavelengths they are intended to receive. An amateur radio operator sets up an antenna line in his backyard in order to receive a signal from across the country. What length should this antenna line be to receive a signal of  $3.0 \times 10^2$  Hz?
- 13.** You hear the siren of a fire engine as you stand on the side of the road. As it approaches, the siren which broadcasts at a frequency of 645 Hz is heard by you as being 660 Hz. How fast is the fire engine traveling?
- 14.** A friend talks to you as she walks past you at a speed of 2.25 m/s. Why do you not notice a Doppler shift in her voice as she passes?
- 15.** If a submarine emits a sonar "ping" underwater and detects an echo 4.00 s later, how far away is the object that reflected the echo?
- 16.** An open tube is filled with water which is slowly drained as a tuning fork of frequency  $f = 1.00 \times 10^3$  Hz is held over the open end. As the water drains, the level of the water is marked as a maximum of sound is heard in the tube. These maxima are detected at distances of 16.7 cm, 33.4 cm and 50.1 cm, measured from the open end of the tube. What is the speed of sound in the air within the tube?
- 17.** A piano tuner is trying to tune one of the piano strings by listening for a beat frequency between the unknown string and a known tuning fork of frequency 262.0 Hz.
- He notices a beat frequency of 4.0 Hz when the string and tuning fork are struck at the same time. What is the frequency of the piano string?
  - After an adjustment, he notices a beat frequency of 0.11 Hz when the string and tuning fork are struck. What is the new frequency of the piano string?
- 18.** In music, the middle C has a frequency of 256 Hz. What frequency is a note that is exactly one octave higher than middle C?

## CHAPTER

## 16

## Supplemental Problems

## Fundamentals of Light

1. An outdoor lamp has a luminous flux of 2500 lm.
  - a. What is the illuminance on the ground if the lamp is mounted at a height of 2.8 m?
  - b. What is the illuminance on a house that is 10.7 m from the lamp?
  - c. What is the luminous intensity of the lamp?
2. A home movie projector has an internal lamp with a luminous flux of 1500 lm.
  - a. How far from the screen should the projector be positioned to obtain a screen illuminance of 3.32 lx?
  - b. What would be the luminous flux of the projector if it produced the same screen illuminance at 4.89 m from the screen?
3. How many lumens are there per candela?
4. A point source of light provides 4.21 lx at 2.1 m.
  - a. What is the luminous intensity of the light source?
  - b. What is the luminous flux of the light source?
5. A certain type of halogen light has a luminous intensity of 15,000 cd. How many times more illuminance does this bulb provide at 1.00 m than a 60-W lightbulb with a luminous flux of 1750 lm?
6. What is the observed change in wavelength of orange light ( $\lambda = 590$  nm) when the light source is moving toward an observer at  $5.66 \times 10^5$  m/s?
7. The primary colors are red, yellow, and blue. Based on the wavelengths below, calculate the range of frequencies for each color of light.
  - a. blue: 455–492 nm
  - b. yellow: 577–597 nm
  - c. red: 622–780 nm
8. Visible light has a frequency that ranges from about  $4.0 \times 10^{14}$  Hz to about  $7.5 \times 10^{14}$  Hz. What is the range of wavelengths for visible light?
9. Find the velocity of the observer for each of the following situations. Assume the light source is stationary in each situation.
  - a. An observer approaches a light source at a velocity that makes red light ( $\lambda = 670$  nm) appear yellow ( $\lambda = 585$  nm).
  - b. An observer approaches a light source at a velocity that makes yellow light ( $\lambda = 585$  nm) appear blue ( $\lambda = 470$  nm).
  - c. An observer approaches a light source at a velocity that makes red light ( $\lambda = 670$  nm) appear blue ( $\lambda = 470$  nm).
10. A source of green light ( $\lambda = 545$  nm) moves toward an observer at 345,000 m/s. What is the frequency of the light from the observer's perspective?
11. Two polarizing filters are placed so that the angle between the polarizing axes is  $45^\circ$ . Find the ratio of the intensity of the light exiting the second filter to the intensity of the light exiting the first filter.

**16 Supplemental Problems***continued*

- 12.** How fast do you have to approach a source of yellow light ( $\lambda = 585 \text{ nm}$ ) to reduce the observed wavelength to  $575 \text{ nm}$ ?
- 13.** A light source has a luminous intensity of  $375 \text{ cd}$ .
- What is its luminous flux?
  - What illuminance does this light source provide at  $2.50 \text{ m}$  from the source?
- 14.** A light source emits light with a wavelength of  $490 \text{ nm}$ . This light is observed to have a wavelength  $15 \text{ nm}$  greater than the original wavelength. Find the relative speed of the source and the observer. Make sure you specify whether they are moving toward or away from each other.
- 15.** Two polarizing filters are set up so that light from a source passes through both of them. The intensity of the light leaving the second filter is  $0.750$  times the intensity of the light leaving the first filter. What is the angle between the filters?
- 16.** A light source generates light with a frequency of  $5.45 \times 10^{12} \text{ Hz}$ . What is the observed frequency of this light if the observer is moving away from the source at  $2.60 \times 10^4 \text{ m/s}$ ?

## CHAPTER

## 17

## Supplemental Problems

## Reflection and Mirrors

1. A light ray strikes a plane mirror at an angle of  $23^\circ$  to the normal. Find the angle of reflection for each of the following scenarios.
  - a. The light source moves so that the angle of incidence decreases by  $11^\circ$ .
  - b. The light source moves so that the angle of incidence increases by  $29^\circ$ .
  - c. The mirror rotates  $20.0^\circ$  around the point where the beam strikes the mirror so that the angle of incidence increases. The mirror rotates on an axis that is perpendicular to the plane of the incident and reflected rays.
2. A light ray strikes a plane mirror at an angle of  $41^\circ$  to the normal. How many degrees must the mirror be rotated so that the angles of incidence and reflection are both zero and the reflected light follows the same path as the incident light?
3. In a curved mirror, a child appears to be 1.00 m tall. The child's actual height is 1.31 m.
  - a. What is the magnification of the image?
  - b. If the child's position is 6.0 m from the mirror, what is the child's image position?
4. A concave mirror magnifies images by a factor of 2.6.
  - a. What is the height of an image formed by a 0.89-m-tall object?
  - b. What is the height of an object that has a 1.8-m-tall image?
  - c. What is the object distance of an image that has a position of  $-2.00$  m?
5. An object is 10.0 cm from a concave mirror with a focal length of 7.00 cm. The object is 5.00 cm tall.
  - a. What is the image position?
  - b. What is the magnification of the image?
  - c. What is the image height?
6. An image in a concave mirror has a position of 18.0 cm, and its object has a position of 15.0 cm. What is the focal length of the mirror?
7. A concave mirror has a focal length of 5.00 cm. An image from the mirror has a position of 12.0 cm. What is the magnification of the image?
8. An image in a concave mirror has a position of 10.0 cm. What is the focal length of the mirror if it has a magnification of  $-\frac{1}{5}$ ?
9. A concave mirror has a radius of 40.0 cm. An object is placed 25.0 cm from the mirror.
  - a. What is the focal length of the mirror?
  - b. What is the image position?
  - c. What is the magnification of the image?
10. A convex mirror has a focal length of 10.0 cm and a magnification of  $\frac{1}{2}$ .
  - a. What is the image position for an object placed 20.0 cm from the mirror?
  - b. If the object is 2.3 cm tall, how tall is its image in the mirror?
11. A concave mirror with a 30.0-cm radius of curvature produces an image that is 24.0 cm in front of the mirror and inverted. Where is the object that produced the image located?

**17 Supplemental Problems***continued*

- 12.** An object that is 10.0 cm from a concave mirror has an image located 15.0 cm from the mirror. What is the focal length of the mirror?
- 13.** An object located 15.0 cm in front of a concave mirror produces an image 60.0 cm in front of the mirror. What is the focal length of the mirror?
- 14.** A concave mirror with a focal length of 25.0 cm produces an image at 75.0 cm. What is the object distance for the object that produced the image?
- 15.** A 5.00-cm-tall object is reflected in a convex mirror with a  $-40.0$ -cm focal length. The image is located 20.0 cm behind the mirror.
- a.** Where is the object located?
- b.** What is the height of the image?
- 16.** In a convex mirror, a 15.0-cm-tall object forms a 7.5-cm-tall image. What is the object distance if the image is located at  $-8.00$  cm?

## CHAPTER

## 18

## Supplemental Problems

## Refraction and Lenses

- A beam of light traveling through air strikes flint glass at an angle of  $31.0^\circ$  to the normal. At what angle does the beam enter the flint glass?
- Light has a speed of  $2.00 \times 10^8$  m/s in clear acrylic.
  - What is the index of refraction of clear acrylic?
  - What is the wavelength of yellow light ( $\lambda = 589$  nm) in clear acrylic?
  - A beam of light traveling through air strikes a block of clear acrylic at an angle of  $29^\circ$  to the normal. At what angle does the light enter the block of clear acrylic?
- A beam of light traveling through water is incident upon an unknown type of glass at an angle of  $45.0^\circ$  to the normal and is refracted at an angle of  $33.6^\circ$  to the normal.
  - What is the index of refraction for the unknown type of glass?
  - What is the speed of light in the unknown type of glass?
- A beam of yellow light has a wavelength of  $1.425 \times 10^{-6}$  m in an unknown medium.
  - What is the index of refraction of the unknown medium?
  - Based on Table 18-1 on page 486 of your textbook, what do you think the unknown substance is?
- An even layer of oil floats on top of water ( $n_{\text{oil}} = 1.15$ ). A beam of light strikes the oil at an angle of  $32.1^\circ$  to the normal. What is the beam's angle of refraction in the water?
- Calculate the critical angles for each of the following situations.
  - a beam of light passing from crown glass into air
  - a beam of light passing from diamond into flint glass
  - a beam of light passing from quartz into water
  - a beam of light passing from water into air
- A beam of light passing from an unknown substance into ethanol has a critical angle of  $63.5^\circ$ .
  - What is the index of refraction of the unknown substance?
  - Use Table 18-1 on page 486 of your textbook to identify the unknown substance.
- A magnifying glass forms a 25.0-mm image of a 4.50-mm thread when the thread is placed 30.0 mm from the lens. What is the focal length of the magnifying glass?
- A student views a friend through a concave lens. The friend is 1.83 m tall and stands 5.00 m from the student with the lens. If the focal length of the lens is 1.00 m, how tall is the virtual image of the friend?
- A convex lens with a focal length of 22.5 cm is used to create a real image of an object placed 51.0 cm from the lens. The height of the object is 20.0 cm.
  - What is the image position?
  - What is the height of the image?

**18 Supplemental Problems***continued*

- 11.** A beam of light has a wavelength of 550 nm. While traveling through an unknown substance, the light has a wavelength of  $5.00 \times 10^{-7}$  m. What is the index of refraction of the unknown substance?
- 12.** A beam of light traveling through water strikes the boundary between the water and air at an angle of  $25^\circ$  to the normal. At what angle does the light enter the air?
- 13.** Light travels at a speed of  $1.85 \times 10^8$  m/s through an unknown medium.
  - a.** What is the index of refraction of the medium?
  - b.** Based on **Table 18-1** on page 486 of your textbook, what do you think the medium is?
- 14.** What is the critical angle for light traveling from quartz into crown glass?
- 15.** An object is located 18.0 cm from a convex lens that has a focal length of 6.0 cm.
  - a.** Where is the image located?
  - b.** What is the orientation of the image?
- 16.** An object is located 24.0 cm from a convex lens. The object is 4.0 cm tall and its image is  $-1.0$  cm tall. Where is the image located?



## CHAPTER

## 19

## Supplemental Problems

## Interference and Diffraction

- Yellow light of a certain wavelength is incident upon two slits separated by  $22.5 \mu\text{m}$ . A screen is placed  $1.20 \text{ m}$  away from the slits. The distance to the first-order bright line is  $31.4 \text{ mm}$ . What is the wavelength of the light?
- A certain laser emits light with a wavelength of  $696 \text{ nm}$ . The laser is directed at a double slit and a screen is placed  $0.900 \text{ m}$  from the slits. The first-order bright line appears  $36.5 \text{ mm}$  from the central bright line. What is the distance between the slits?
- Green light with a wavelength of  $545 \text{ nm}$  is incident upon two slits separated by  $18.0 \mu\text{m}$ . A screen is set up to view the interference pattern produced and the first-order bright line is  $26.4 \text{ mm}$  from the central bright line. How far is the screen from the double slit?
- A wire coat hanger and a mild solution of soap and water can be used to create large soap bubbles. These bubbles have a multi-colored appearance due to thin-film interference. If the index of refraction of the soapy water is  $1.4$  what is the minimum thickness of the soap bubble when blue light with a wavelength of  $488 \text{ nm}$  is reflected?
- A single-slit diffraction experiment is set up using light from a He-Cd laser ( $\lambda = 442 \text{ nm}$ ). A screen is placed  $0.980 \text{ m}$  from the slit and the central bright line produced by the experiment has a width of  $21.3 \text{ cm}$ . What is the width of the slit?
- A single-slit diffraction experiment is set up using a slit with a width of  $10.0 \text{ cm}$ . The screen is placed  $0.900 \text{ cm}$  from the slit and the distance from the central bright band to the first dark line is  $0.55 \text{ cm}$ . What is the wavelength of the light used?
- A single-slit diffraction experiment is performed using a He-Ne laser ( $\lambda = 633 \text{ nm}$ ) and the setup in the figure below. What will be the width of the central bright band?

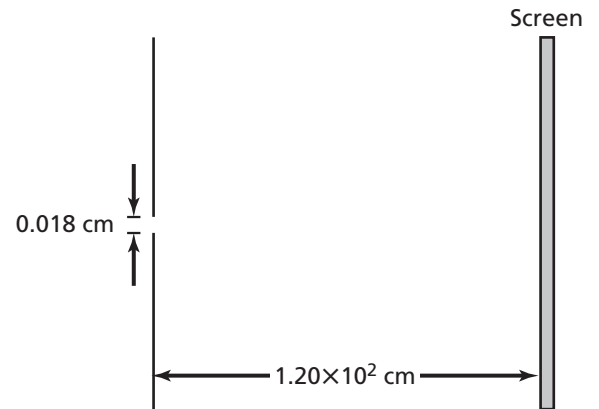

- A grating spectroscopy is used to analyze light of an unknown wavelength. The slits of the grating are  $2.4 \mu\text{m}$  apart and the angle between the central bright line and the first-order bright line is  $15.8^\circ$ . What is the wavelength of the light?
- A spectroscopy uses a grating with  $11,500 \text{ lines/cm}$ . At what angle will light of wavelength  $485 \text{ nm}$  have its first-order bright line?
- The aperture through which light enters the human eye is called the iris. The average human iris has a diameter of  $5 \text{ mm}$ . What is the physical limit of the height of an object viewed from  $6.0 \text{ m}$  away?

**19 Supplemental Problems***continued*

- 11.** Coherent light of wavelength 642 nm is incident upon a pair of slits separated by  $21\ \mu\text{m}$ . If a screen is placed 0.550 m from the slits, how far from the central bright band is the second-order bright band?
- 12.** Light of an unknown wavelength falls on two slits separated by  $1.90 \times 10^{-5}\ \text{m}$ . A first-order bright band appears 12.4 mm from the central bright band on a screen that is placed 0.450 m from the slits. Find the wavelength of the light.
- 13.** A thin layer of oil floats on water. When light strikes the oil, colored bands are produced. One of the colors is blue ( $\lambda = 490\ \text{nm}$ ). If the index of refraction of oil is 1.45, what is the minimum thickness that could have produced this color?
- 14.** Light of wavelength 612 nm falls on a single slit  $8.5 \times 10^{-5}\ \text{m}$  wide. The slit is 81 cm from a screen. How wide is the central bright band?
- 15.** Light of an unknown wavelength falls on a single slit  $9.00 \times 10^{-5}\ \text{m}$  wide. A 14.1 mm wide bright band is produced on a screen 85 cm away. What is the wavelength of the light?
- 16.** When light of wavelength 540 nm shines on a diffraction grating, lines spaced at 0.54 m are produced on a screen 95 cm away. What is the spacing between the slits in the diffraction grating?

CHAPTER

20

Supplemental Problems

Static Electricity

1. A point charge of  $+1.23 \times 10^{-8}$  C and a point charge of  $-2.0 \times 10^{-6}$  C are separated by 30.0 cm. What is the attractive force between the charges?
2. Two identical positive charges separated by 12.5 cm exert a repulsive force of 1.24 N on each other. What is the magnitude of the charges?
3. A metal sphere has a mass of 1.22 kg and carries a charge of  $-3.34$  nC. Determine the size of the charge required to levitate the sphere 1.00 cm above the charge.

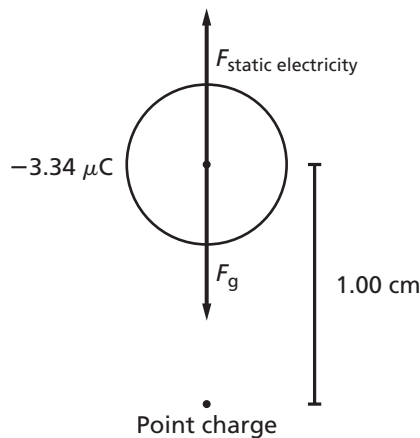

4. Three charged particles are placed in a line, as shown in the figure below.
  - a. Find the magnitude and direction of the force on particle A.
  - b. Find the magnitude and direction of the force on particle B.

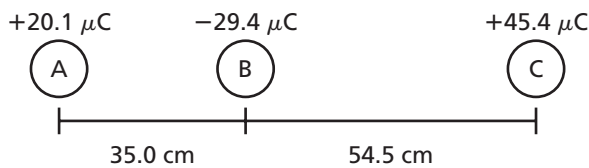

5. Two negatively charged particles are separated by 89.0 cm. One particle has 4.2 times the charge of the other particle. If the repulsive force between the particles is 0.097 N, what is the magnitude of the charge on each particle?
6. A particle with a charge of  $1.01 \mu\text{C}$  and a particle with a charge of  $0.907 \mu\text{C}$  exert a force of 4.56 N on each other. What is the distance between the two particles?
7. Three charged particles are arranged as shown in the figure below. Calculate the magnitude and direction of the force experienced by particle B.

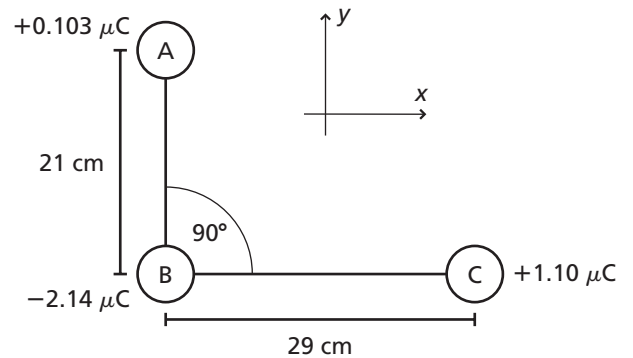

8. A tiny metal sphere carrying a charge of  $-43.6$  nC is touched to an identical neutral metal sphere. The spheres are then placed 1.02 cm apart. What is the magnitude of the repulsive force between the two spheres?
9. Two point charges are separated by a distance of 23 cm. One of the charges has a magnitude of  $+1.23 \mu\text{C}$ , and there is an attractive force of 1.8 N between the charges. What is the magnitude of the negative charge?

**20 Supplemental Problems***continued*

- 10.** What is the force of attraction between an electron and a proton separated by 27.0 nm?
- 11.** Two electrons are located only 2.5 nm apart.
- What is the magnitude of the force between these charged particles?
  - Is the force attractive or repulsive?
- 12.** Calculate the repulsive force between two protons in the nucleus of an atom of iron separated by only  $4.0 \times 10^{-15}$  m.
- 13.** The electron and proton in a hydrogen atom exert an electric force of  $8.1 \times 10^{-8}$  N on each other. What is the distance between them?
- 14.** Two protons are located 1.0 cm apart. Which force has the greater magnitude,  $\frac{1}{m}$ : force due to charge or gravitational force?
- 15.** Three point charges of  $-3.4 \mu\text{C}$  each are arranged at the points of an equilateral triangle with sides of length 5.0 cm, as shown in the figure below. What is the magnitude of the force acting on one of the charges?

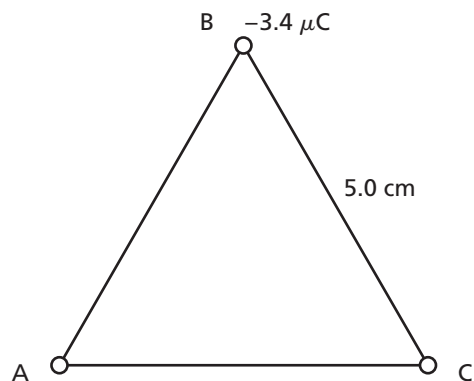

CHAPTER

# 21 Supplemental Problems

## Electric Fields

1. A test charge in an electric field of strength 21.45 N/C experiences a force of 5.10 N. What is the magnitude of the test charge?
2. A test charge of  $-3.00 \mu\text{C}$  is placed in an electric field of 121 N/C, as shown in the figure below. What are the magnitude and direction of the force on the test charge?

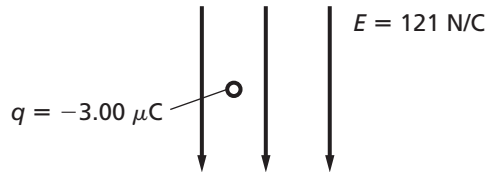

3. What is the magnitude of an electric field that exerts 39.0 N of force on a  $4.5 \times 10^{-5}\text{-C}$  test charge?
4. The potential difference between the two plates below is 520 V.
  - a. What is the strength and direction of the electric field between the two plates?
  - b. How much work is required to move one more electron to the negative plate?



5. A 3.3-mC charge is moved through a 150-V potential difference.
  - a. How much work is required to move the charge?
  - b. If the charge is moved 0.750 cm, what is the strength of the electric field where the charge is moved?

6. A point charge of unknown magnitude is moved through a 210-N/C electric field.
  - a. If the charge is negative and positive work is done on the system, in what direction relative to the electric field lines is the charge moved?
  - b. If the charge is positive and negative work is done on the system, in what direction relative to the electric field lines is the charge moved?
  - c. Through what potential difference has the charge moved if it is moved 1.9 cm?
  - d. If +98 J of work is required to move the charge 1.9 cm against the electric field lines, what is the sign and magnitude of the charge?
7. A positive test charge is moved 5.6 cm against a 75-N/C electric field. Through what potential difference has the charge been moved?
8. What is the capacitance of a capacitor that requires a potential difference of 54 V to store  $67.8 \mu\text{C}$  of charge?
9. How much voltage is required for a capacitor with a capacitance of  $0.750 \mu\text{F}$  to store  $2.3 \mu\text{C}$  of charge?
10. The same voltage is applied to both capacitors A and B, but capacitor A stores three times more charge than capacitor B. What is the ratio of the capacitance of capacitor A to the capacitance of capacitor B?

**21 Supplemental Problems***continued*

- 11.** A helium nucleus consisting of two protons and two neutrons passes through a detector with an electric field strength of  $1.50 \times 10^6$  N/C. What is the magnitude of the force experienced by the helium nucleus?
- 12.** An unknown charge is brought within 8.0 cm of a standard test charge of  $-5.0 \times 10^{-9}$  C. At this distance, an electric field strength of  $4.65 \times 10^{-2}$  N/C is measured. What is the value of the unknown charge?
- 13.** In 1 s,  $2.50 \times 10^{18}$  electrons pass from one charged plate to another parallel charged plate.
- If the potential difference between the parallel plates is  $1.0 \mu\text{V}$ , how much work is done moving this quantity of electrons between the two plates?
  - With an electric field strength of  $6.0 \times 10^{-4}$  N/C measured between the plates, how far apart are these parallel plates?
- 14.** An oil drop is suspended in an electric field of  $1.92 \times 10^5$  N/C between two charged plates as part of a Millikan oil-drop experiment. The oil drop has a mass of  $1.57 \times 10^{-11}$  g and the charged plates of the apparatus are exactly 1.00 cm apart.
- What is the potential difference between the two charged plates?
  - What is the net charge on the oil drop? How many excess electrons are on this oil drop?
  - Which plate is positively charged and which plate is negatively charged? What would happen if the charges were reversed?
- 15.** A  $0.5\text{-}\mu\text{F}$  capacitor is able to store  $7.2 \times 10^{-10}$  C of charge with an electric field strength of 0.33 N/C between its plates. How far apart are these plates?
- 16.** Most capacitors are measured in terms of microfarads,  $\mu\text{F}$ , or picofarads, pF, because the unit of capacitance, the farad, is a relatively large unit. Given a 1-F capacitor with plates separated by 1.0 mm and an electric field strength of 1 N/C, calculate the number of electrons resting on the plates of this capacitor.

CHAPTER

22

Supplemental Problems

Current Electricity

1. A 9.0-V battery is connected to a lightbulb, as shown below.
  - a. How much power is delivered to the lightbulb?
  - b. How much energy will the bulb use in 1 h?
  - c. How long would the bulb have to stay on to use 1 kWh of energy?

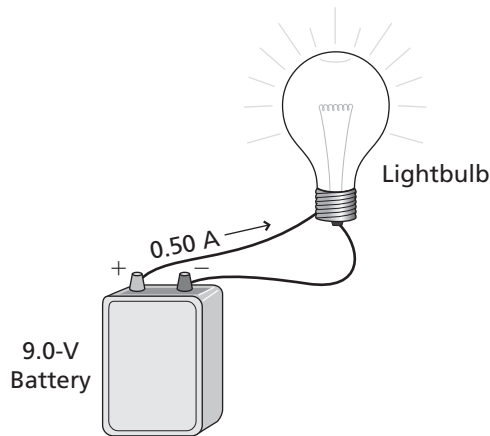

2. A 60-W lightbulb is connected to a 115-V power source.
  - a. What is the current through the lightbulb?
  - b. What is the resistance of the lightbulb?
3. A circuit is set up as shown in the diagram at the top right.
  - a. What should the reading on the ammeter be?
  - b. What should the reading on the voltmeter be?
  - c. How much power is delivered to the resistor?

- d. How much energy is delivered to the resistor per hour?

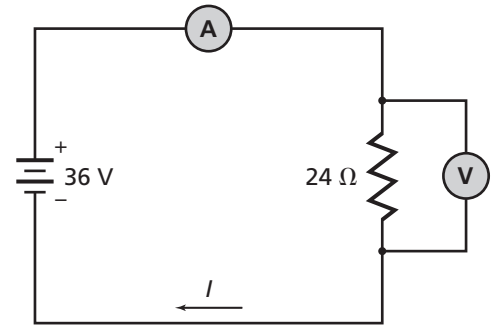

4. A microwave draws a 15.0-A current from a 120-V power source.
  - a. How much power is delivered to the microwave?
  - b. How much energy does the microwave use to heat food for 1 min?
5. A circuit is set up as shown in the diagram below.
  - a. What is the resistance of the resistor in the circuit?
  - b. What should be the reading on the voltmeter?
  - c. How much power is delivered to the resistor?
  - d. How much energy is delivered to the resistor per hour?

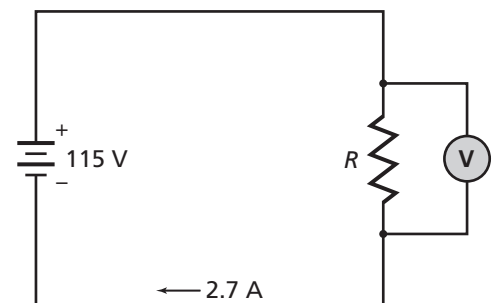

**22 Supplemental Problems***continued*

- 6.** A 100-W lightbulb is turned on for two-fifths of the time for 30 days. At a price of \$0.090 per kWh, how much does the lightbulb cost to run during the 30 days?
- 7.** A current of 0.85 A is measured through a 27- $\Omega$  resistor for 1.00 h. How much heat does the resistor generate?
- 8.** A 60-W lightbulb has a resistance of 240  $\Omega$ . What is the current in the lightbulb?
- 9.** What is the current through an 80.0- $\Omega$  resistor if the voltage drop across the resistor is 20.0 V?
- 10.** A 60-W lightbulb and a 100-W lightbulb both are connected to a 120-V power source. Which bulb has the greater resistance?
- 11.** A 12-V battery is used to power a  $3.0 \times 10^2$  mA video camera.
- How much power does the battery provide to the camera?
  - How much energy does the camera use in 1.0 s?
  - How much energy does the camera use in 1.0 h?
  - How long would it take the video camera to use 1 kWh of energy?
- 12.** A 60-W bulb powered by a 120.0-V source has a resistance of 5.0  $\Omega$  at room temperature and 100.0  $\Omega$  at operating temperature.
- What is the current when a 60-W bulb is turned on at room temperature?
  - What is the power of this room-temperature bulb?
  - What is the current when the 60-W bulb is at operating temperature?
  - What is the power of the bulb at operating temperature?
- 13.** A 240-V water heater has a resistance of 15  $\Omega$ .
- What is the power of the heater?
  - What thermal energy is supplied by the heater in 15 min?
  - Compare the power of the same 240-V water heater to a 120-V water heater, also with a resistance of 15  $\Omega$ .
  - Compare the thermal energy of the 240-V water heater to a 120-V heater in a 15-min period?
- 14.** How much power is dissipated in wires that have a current of 50.0 A and a resistance of 0.015  $\Omega$ ?
- 15.** A long-distance high-tension wire uses 500,000 V.
- What is the power output of these wires in watts, kilowatts, and megawatts if the current is 20 A?
  - What is the power dissipated in the wires if the resistance is 0.015  $\Omega$ ?
- 16.** Photovoltaic panels provide power to a home each sunny day. The resistance of the wires in this system is 0.5  $\Omega$ . If the power consumption of a computer in the home is 200 W, what current does the computer cause through the wires?
- 17.** Compare the energy a 120-W bulb uses per hour with the energy use in 1.0 hour of a 60-W bulb.
- 18.** How much money would be saved by turning off one 100.0-W lightbulb 3.0 h/day for 365 days if the cost of electricity is \$0.12 per kWh?
- 19.** How much money can be saved by turning off a 500.0-W television set for 3.0 h/day for 365 days at \$0.12 per kWh?
- 20.** How much does it cost to operate a 1000.0-W blow dryer for 10.0 minutes at \$0.12 per kWh?



CHAPTER

23

Supplemental Problems

Series and Parallel Circuits

1. Three  $12.0\text{-}\Omega$  resistors are connected in series to a  $50.0\text{-V}$  power source.
  - a. What is the equivalent resistance of the circuit?
  - b. What is the current in the circuit?
  - c. What is the voltage drop across each resistor?
2. Three  $15.0\text{-}\Omega$  resistors are connected in parallel to a  $45.0\text{-V}$  power source.
  - a. What is the equivalent resistance of the circuit?
  - b. What is the current in the circuit?
  - c. What is the current through each resistor?
3. Two resistors are connected in series to a power source. The voltage drop across the first resistor is  $5.40\text{ V}$  and the voltage drop across the second resistor is  $9.80\text{ V}$ . The current through the circuit is  $1.20\text{ A}$ .
  - a. What is the resistance of each of the resistors?
  - b. What is the equivalent resistance of the circuit?
4. What is the equivalent resistance of the circuit shown below? What is the current in the circuit? What is the voltage drop across the two resistors wired in parallel?
5. A  $10.0\text{-}\Omega$  resistor, a  $20.0\text{-}\Omega$  resistor, and a  $30.0\text{-}\Omega$  resistor are wired in parallel and connected to a  $15.0\text{-V}$  power source. What is the equivalent resistance of the circuit?
6. A  $12\text{-}\Omega$  and an  $18\text{-}\Omega$  resistor are connected to a  $48\text{-V}$  power source.
  - a. What is the equivalent resistance of the circuit if the resistors are connected in series?
  - b. What is the equivalent resistance of the circuit if the resistors are connected in parallel?
7. A voltage divider is made from a  $9.0\text{-V}$  battery. Two resistors are connected in series to the battery. If one resistor has a resistance of  $24\ \Omega$  and the voltage drop across the other resistor must be  $4.0\text{ V}$ , what is the resistance of the second resistor?
8. A circuit is constructed, as shown in the figure below. The voltmeter reads  $63.0\text{ V}$ .
  - a. Which resistor dissipates the most energy per second?
  - b. What is the voltage of the power source?

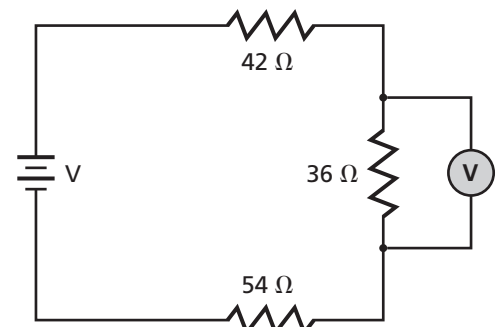
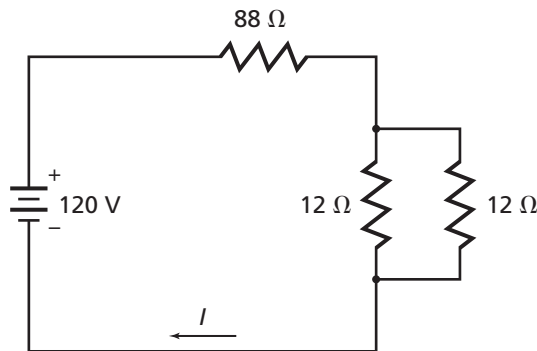

9. Three identical resistors are connected in parallel across a power source. Their equivalent resistance is  $8.00\ \Omega$ . What is the resistance of each resistor?

**23 Supplemental Problems***continued*

- 10.** A  $10.0\text{-}\Omega$  resistor and a  $20.0\text{-}\Omega$  resistor are connected in series with a potentiometer and a  $9.0\text{-V}$  battery.
- What should the potentiometer be set at for a total equivalent resistance of  $50.0\ \Omega$  in this circuit?
  - If the potentiometer is set at  $32.0\ \Omega$ , what would be the current in this circuit?
  - If the potentiometer were turned so that the resistance increases, what would happen to the current?
- 11.** A piece of lab equipment must be connected to a standard  $6.0\text{-V}$  dry cell. The manual for the equipment says that this device has an internal resistance of  $0.10\ \Omega$  and cannot handle more than  $2.5\ \text{A}$  of current.
- What value of resistor can you connect in series with this device that would allow it to be connected to the power source?
  - What three resistors of equal value could you use in series instead of the single resistor determined in part a?
- 12.** Two resistors are connected in parallel to a  $3.0\text{-V}$  power source. The first resistor is marked as  $150\ \Omega$  but the second resistor is unmarked and unknown. Using an ammeter, you measure the current passing through the unknown resistor as  $45.0\ \text{mA}$ .
- What is the value of the second resistor?
  - What is the current passing through the  $150\text{-}\Omega$  resistor?
  - What is the total current passing through this power source?

- 13.** A circuit is constructed, as shown in the figure at right. What is the value of  $R_3$ ?

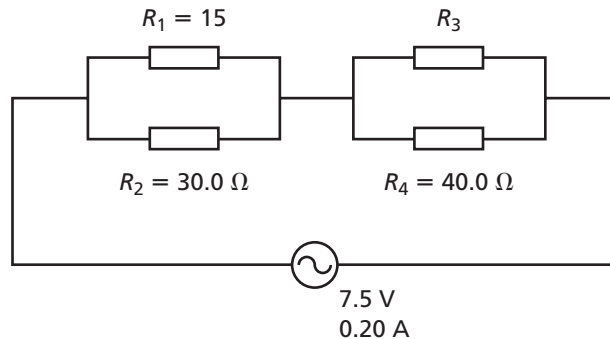

- 14.** What is the equivalent resistance of the resistors in the circuit as shown in the figure at right?

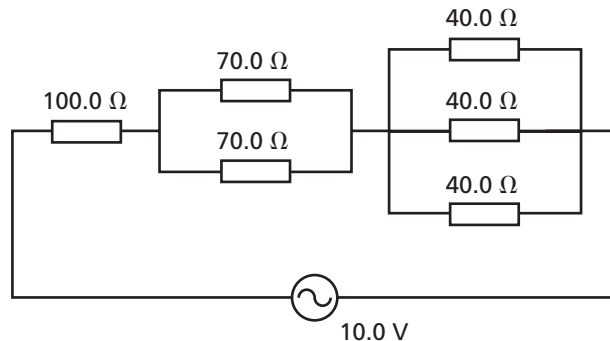

## CHAPTER

## 24

## Supplemental Problems

## Magnetic Fields

1. A 1.20-cm wire carrying a current of 0.80 A is perpendicular to a 2.40-T magnetic field. What is the magnitude of the force on the wire?
2. A 24.0-cm length of wire carries a current and is perpendicular to a 0.75-T magnetic field. If the force on the wire is 1.80 N, what is the current in the wire?
3. A 0.50-cm length of wire carries a current and is perpendicular to a magnetic field, as shown below.
  - a. What is the direction of the force on the wire?
  - b. What is the magnitude of the force on the wire?

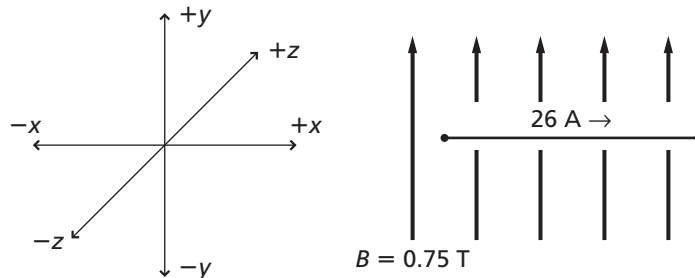

4. A 4.50-cm length of wire carries a 2.1-A current and is perpendicular to a magnetic field. If the wire experiences a force of 3.8 N from the magnetic field, what is the magnitude of the magnetic field?
5. A length of wire carrying a current of 2.0 A is perpendicular to a 6.5-T magnetic field. What is the length of the wire if it experiences a force of 2.99 N?
6. An electron beam is perpendicular to a 0.020-T magnetic field. What is the force experienced by one electron if the beam has a velocity of  $9.8 \times 10^3 \text{ m/s}$ ?
7. A proton experiences a force of  $6.9 \times 10^{-15} \text{ N}$  when it travels at a right angle to a 1.35-T magnetic field. What is the velocity of the proton?

# 24 Supplemental Problems

continued

8. A doubly ionized particle travels through a magnetic field, as shown in the figure below. What is the force experienced by the particle?

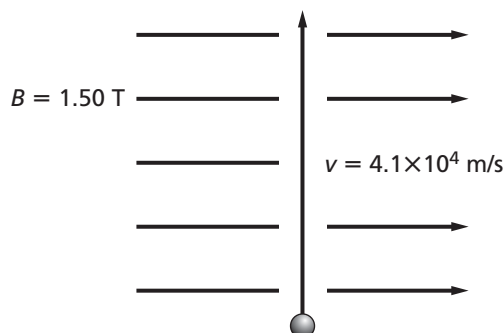

9. A positively charged particle travels at a right angle through a 3.00-T magnetic field with a velocity of  $4.50 \times 10^5$  m/s. If the particle experiences a force of  $4.32 \times 10^{-13}$  N as it travels through the magnetic field, what is the charge on the particle?
10. An electron traveling  $8.6 \times 10^7$  m/s at a right angle to a magnetic field experiences a force of  $2.9 \times 10^{-11}$  N. What is the strength of the magnetic field?
11. A screen of ten straight wires is laid horizontally in a magnetic field of 24.0 T oriented at right angles to the wires. Each wire carries a current of 12 mA and is 50 cm long.
- What is the total force experienced by this screen?
  - As the current in the wires increases, what happens to the force experienced by the screen?
12. A 15-cm length of wire is suspended horizontally in a magnetic field of 8.0 T oriented at a right angle to the wire in such a way that the force experienced by this wire acts in the upward direction.
- If the wire has a mass of 3.0 g and is able to move freely, what current running through this wire is necessary to lift the wire off the ground?

- If this wire is turned  $90^\circ$  so that the direction of the current lines up with the magnetic field, what happens to the force?

13. A square loop of current-carrying wire is placed horizontally in a magnetic field that also is oriented horizontally, as shown in the figure below. Describe the forces on each segment of wire and the resulting force or motion if the wire is able to move freely.

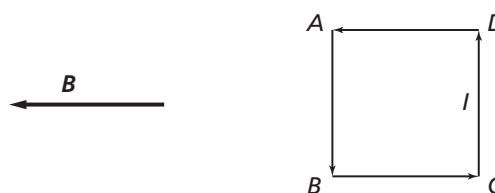

14. A negatively charged particle passes through a magnetic field of strength 0.40 T perpendicular to the direction of travel. By measuring its deflection, you calculate that the particle experiences a force of  $-9.2 \times 10^{-12}$  N.
- How fast is this particle moving?
  - What force would a neutral particle experience under these same conditions?
15. The speed of charged subatomic particles may be calculated by measuring their curved orbits due to centripetal forces when passing through a strong magnetic field. If a proton circles in an orbit of 3.10 cm within a magnetic field of 8.0 T, how fast is this proton moving?
16. How strong would a magnetic field have to be to offset the force of gravity acting on an electron traveling at a speed of  $9.5 \times 10^7$  m/s?

## CHAPTER

## 25

## Supplemental Problems

## Electromagnetic Induction

- A 21.0-cm length of wire moves perpendicular to a 2.45-T magnetic field at 3.5 m/s.
  - What is the magnitude of the  $EMF$  induced in the wire?
  - The wire is part of a circuit with a total resistance of  $3.0 \Omega$ . What is the current through the wire?
- An induced  $EMF$  of 0.089 V is induced in a 5.0-cm wire when it is moved perpendicular to a magnetic field at 2.1 m/s. What is the magnitude of the magnetic field?
- An unknown length of wire moves perpendicular to a 3.40-T magnetic field with a velocity of 12.0 m/s. If the induced  $EMF$  is 49 V, what is the length of the wire?
- A 0.9-T magnetic field points  $40.0^\circ$  north of west. A 34-cm wire perpendicular to the surface of Earth moves directly westward at a speed of 8.9 m/s.
  - What is the component of the velocity that is perpendicular to the magnetic field?
  - What  $EMF$  is induced in the wire?
- An AC generator produces a maximum voltage of  $3.00 \times 10^2$  V.
  - What is the effective voltage in a circuit connected to the generator?
  - If the resistance of the circuit is  $53 \Omega$ , what is the effective current in the circuit?
- A straight wire that is 28.0 cm long moves through a magnetic field of 2.0 T at a constant speed of 3.25 m/s in a direction that is  $45^\circ$  from the direction of the magnetic field. If the wire is  $0.30 \Omega$ , what is the induced current in the wire?
- A lightbulb is connected to an AC generator, as shown below.
  - What is the resistance of the bulb?
  - What is the maximum current through the bulb?
  - What is the peak power dissipated by the bulb?
- A step-up transformer has 50 turns on its primary coil and 2000 turns on its secondary coil. The primary circuit is supplied with an effective AC voltage of 150 V.
  - What is the voltage in the secondary circuit?
  - If the current in the secondary circuit is 0.24 A, what is the current in the primary circuit?
- A step-down transformer has 3000 turns on its primary coil and 20 turns on its secondary coil. The primary circuit is supplied with an effective AC voltage of 325 V.
  - What is the voltage in the secondary circuit?
  - If the current in the primary circuit is 1.25 A, what power is drawn by the primary circuit?
  - Assuming the transformer is perfectly efficient, what power is supplied to the secondary circuit?

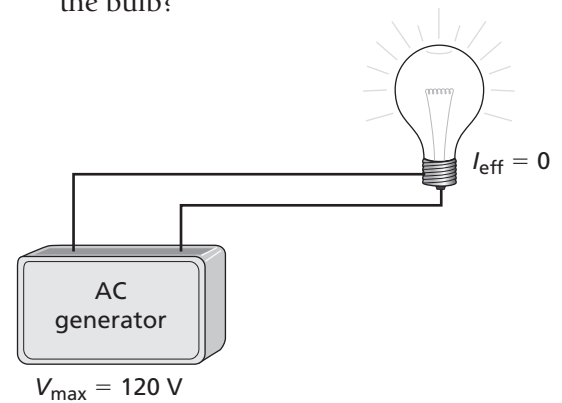

**25 Supplemental Problems***continued*

- 10.** The primary coil of a transformer has 60 turns. It is connected to an AC power supply with an effective voltage of 120 V. Calculate the number of turns on the secondary coil needed to produce 45 V in the secondary circuit.
- 11.** A 2.0-kW transformer has an input voltage of  $8.00 \times 10^2$  V and an output current of 24 A. What is the ratio of turns on the secondary coil to turns on the primary coil?
- 12.** A generator produces an average power output of 80.0 W and includes an internal resistance of  $0.50 \Omega$ .
- What is the effective current from this generator?
  - What is the maximum current from this generator?
- 13.** A transformer is needed to bring a power source of 10.0 V up to a usable value of 12.0 V.
- What is the ratio of the number of turns on the primary and secondary coils necessary to achieve the desired output of 12.0 V? Give your answer in a number of whole turns of the included coils.
  - With a transformer such as this stepping up the voltage of the power source, what happens to the current from that same source?
- 14.** A transformer is constructed with 20 turns on the primary coil and 100 turns on the secondary coil.
- With a primary voltage of 6.0 V, what is the resulting secondary voltage?
  - Twenty turns each are added to the primary and secondary coils. What is the new secondary voltage?
  - Explain why adding the same number of turns to both primary and secondary coils changes the secondary voltage produced.
- 15.** Two different transformers both step up a 2.5-V source to a usable voltage of 10.0 V. You can see that the first transformer has eight turns on its primary coil and the second transformer has 50 turns on its primary coil but both secondary coils are hidden from view.
- Calculate the number of turns on each secondary coil.
  - How can two very different transformers produce the same results?
- 16.** A power source produces 8.4 A of current with an internal resistance of  $0.60 \Omega$ . This power source is connected to a transformer with 35 turns on its primary coil and 1000 turns on its secondary coil. What is the average power output of this system when connected?

## CHAPTER

## 26

## Supplemental Problems

## Electromagnetism

1. Electrons moving at a speed of  $1.8 \times 10^6$  m/s travel undeflected through crossed electric and magnetic fields. If the strength of the electric field is  $4.2 \times 10^3$  N/C, what is the strength of the magnetic field?
2. A beam of doubly ionized particles is accelerated by a 95-V potential difference and through a magnetic field of 0.090 T.
  - a. If the particles are nitrogen ions ( $m = 2.3260 \times 10^{-26}$  kg), what is the radius of the beam's path?
  - b. If the beam's path has a radius of 6.28 mm, what is the mass of the ion?
3. The charge-to-mass ratio of a particle is  $4.81 \times 10^7$  C/kg. The particle moves at a velocity of  $4.5 \times 10^4$  m/s through a field of 0.013 T.
  - a. What is the radius of the particle's path?
  - b. How strong would the magnetic field have to be to give the particle's path a radius of 30.0 mm?
4. A proton ( $m = 1.67 \times 10^{-27}$  kg) enters a magnetic field of strength 0.021 T moving at  $4.33 \times 10^3$  m/s. What is the radius of the proton's path?
5. A beam of electrons follows a circular path with a radius of 18.01 mm in a magnetic field of strength 0.00900 T. What is the speed of the electrons?
6. A certain FM radio station broadcasts its signal at 102.7 MHz. What is the best length for an antenna designed specifically to receive signals from this radio station?
7. An ion in a mass spectrometer is accelerated through a voltage of 45 V. The ion has a mass of  $6.634 \times 10^{-26}$  kg. It passes through a magnetic field of strength 0.080 T and its path has a radius of 53.99 mm.
  - a. What is the charge on the ion?
  - b. How many electrons were removed to create this charge on the ion?
8. An electromagnetic wave has a frequency of  $5.00 \times 10^{14}$  Hz as it travels through a vacuum. When the same wave travels through glass, it has a wavelength of  $2.24 \times 10^{-7}$  m.
  - a. What is the speed of the wave in glass?
  - b. What is the dielectric constant of the glass?
  - c. What would the speed of the wave be in a material with a dielectric constant of 42.5?
9. A sample containing singly ionized oxygen ( $m = 2.6569 \times 10^{-26}$  kg/atom) and fluorine ( $m = 3.1549 \times 10^{-26}$  kg/atom) are run through a mass spectrometer. The ions are accelerated with a potential difference of 27 V and pass through a magnetic field of 0.091 T.
  - a. What is the radius of the oxygen ion's path?
  - b. How much larger or smaller is the radius of the fluorine ion's path?
10. A spectral analysis of a substance yields electromagnetic waves of frequencies in the  $6.52 \times 10^{14}$  Hz range. What color do these spectral lines appear?

**26 Supplemental Problems***continued*

- 11.** An ion beam passes through crossed electric and magnetic fields without deflection. The electric field is 2340 N/C and the magnetic field is 0.026 T. When the electric field is turned off, the beam's path takes on a curvature with a radius of 36.1298 mm.
- What is the mass-to-charge ratio of the particle in question?
  - Assuming the particle is singly ionized, what is the mass of the particle?
- 12.** Positively charged sodium ions are tracked as they travel through a magnetic field of strength 0.85 T with a velocity of  $4.0 \times 10^6$  m/s. The observed radius of their circular path through this magnetic field is 1.12 m. What is the mass of a single sodium ion?
- 13.** A mass spectrometer is capable of observing the curved track of a particle up to a radius of 5.0 cm using a magnetic field strength of 4.5 T. What voltage is necessary to measure the charge-to-mass ration of a proton?
- 14.**
- What is the speed of a light wave with a wavelength of 640 nm in water? The dielectric constant for water is  $K_{\text{water}} = 78$ .
  - What is the frequency of this light wave in water compared to its frequency in a vacuum?
- 15.** A dish radio antenna with a diameter of 55 m is used to receive electromagnetic signals from deep space. What frequency is this antenna best suited to detect?
- 16.**
- With a frequency of  $10^{18}$  Hz, are X rays visible to the unaided human eye?
  - In terms of the dielectric constant, explain why X rays will pass through your body but will not pass through bone and metal, allowing internal details to show up on photographic plates.



## CHAPTER

## 27

## Supplemental Problems

## Quantum Theory

1. What is the potential difference needed to stop electrons with a kinetic energy of  $5.6 \times 10^{-18}$  J?
2. The threshold frequency of cesium is  $5.2 \times 10^{14}$  Hz.
  - a. How much work, expressed in joules, must be done to free an electron from the surface of cesium?
  - b. What is the maximum kinetic energy (in eV) of electrons emitted when cesium is exposed to light with a frequency of  $7.4 \times 10^{14}$  Hz?
3. A proton is held in a trap with a kinetic energy of 0.65 eV.
  - a. What is the velocity of the proton?
  - b. What is the de Broglie wavelength of the proton?
4. The work function of a metal is 7.3 eV.
  - a. Calculate the threshold frequency of the metal.
  - b. What is the maximum kinetic energy of an electron ejected from the metal when it is exposed to ultraviolet light with a wavelength of  $1.1 \times 10^{16}$  Hz?
5. An electron is moving at  $4.50 \times 10^5$  m/s.
  - a. What is the de Broglie wavelength of the electron?
  - b. If the electron was accelerated from rest, what was the potential difference?
6. A bowling ball with a mass of 5.5 kg is moving with a speed of 5.0 m/s. Calculate the de Broglie wavelength of the bowling ball.
7. A photon of ultraviolet light has a frequency of  $9.00 \times 10^{14}$  Hz.
  - a. What is the momentum of the photon?
  - b. What is the wavelength of the photon?
8. Electrons are accelerated through a potential difference of  $7.20 \times 10^4$  V in an electron microscope.
  - a. What is the wavelength of the electrons?
  - b. How does this wavelength compare with the wavelengths of visible light?
9. A particle is accelerated through a potential, resulting in a de Broglie wavelength of  $8.54 \times 10^{-12}$  m.
  - a. What is the voltage if the particle is a proton?
  - b. What is the voltage if the particle is an electron?
10. An electron in a computer monitor crosses a potential difference of  $3.5 \times 10^4$  V.
  - a. What is the velocity of the electron?
  - b. What is the de Broglie wavelength of the electron?
11. Calculate the de Broglie wavelength of a 75,000-kg jet airplane with a velocity of 200 m/s.
12. Molybdenum has a work function of 4.20 eV.
  - a. What is the threshold wavelength of the incident light?
  - b. What is the stopping potential of the photoelectrons emitted from molybdenum if the incident light has a wavelength of  $2.00 \times 10^2$  nm?
  - c. What is the change in the stopping potential if the wavelength of the incident light is reduced to  $1.00 \times 10^2$  nm?

**27 Supplemental Problems***continued*

- 13.** What energy is radiated by an atom vibrating at a frequency of  $4.0 \times 10^{14}$  Hz as its energy falls from the  $n = 3$  state to  $n = 1$  state?
- 14.** A radium nucleus undergoes nuclear decay by emitting a beta particle with a kinetic energy of  $3.49 \times 10^{-13}$  J. Express the particle's energy in MeV.
- 15.** What minimum potential difference will stop electrons moving at a speed of  $1.54 \times 10^6$  m/s?
- 16.** A photocell with a cadmium electrode fails to emit photoelectrons if illuminated by light with wavelengths longer than 328 nm. What is the work function of cadmium in eV?
- 17.** When illuminated with ultraviolet light of wavelength 231 nm, the maximum kinetic energy of the photoelectrons emitted from a zinc electrode is 1.25 eV. What is the threshold frequency of the light that will cause the emission of photoelectrons from zinc?
- 18.** The wavelength of an X ray scattered by an electron is 0.0195 nm.
- a.** What is the momentum of the scattered X ray?
- b.** If the wavelength of the incident X ray was 0.0185 nm, what is the change in momentum of the electron?
- 19.** At what speed would an electron have a wavelength similar to that of a photon of ultraviolet light ( $1.00 \times 10^{-8}$  m)?
- 20.** Light of wavelength 345 nm causes electrons to be ejected from a potassium cathode. What is the de Broglie wavelength of the ejected electrons? The work function of potassium is 2.0 eV.

## CHAPTER

## 28

## Supplemental Problems

## The Atom

- The energy of a calcium atom drops from 5.58 eV above the ground state to 4.13 eV above the ground state.
  - What is the wavelength of the photon emitted by the transition?
  - What is the frequency of the photon?
- For a hydrogen atom in the  $n = 2$  Bohr orbital, calculate the radius of the orbital.
- For a hydrogen atom,
  - Determine the energy associated with the third and sixth energy levels.
  - What is the energy of a photon emitted as the electron drops from the sixth level to the third level?
  - What is the wavelength of the photon emitted by the transition?
- How much energy must be supplied to a hydrogen atom to excite its electron from energy level 2 to energy level 6?
  - What is the wavelength of the photon that supplies the energy for this transition?
- How much energy in eV must be absorbed by an electron in the ground state of a helium atom in order for it to jump to the fifth energy level?
  - An electron energy transition in a helium atom emits a photon with a wavelength of  $1.64 \times 10^{-7}$  m. What change of energy levels did the electron experience?
  - A photon with a wavelength of  $2.43 \times 10^{-8}$  m strikes a helium atom and is absorbed. What corresponding electron energy transition occurs?
- The atomic emission spectrum of helium has a prominent line at an infrared wavelength of  $1.08 \times 10^{-7}$  m.
  - What causes this light emission?
  - Why does the calculated value not match an energy transition on the table exactly?
- A photon with a wavelength of 20.8 nm strikes a helium atom, ionizing it by ejecting an electron from the ground state. What is the kinetic energy of the electron, in joules, assuming that the electron receives all the excess energy?

Use the values in Table 28-1 to answer questions 5–7.

Table 28-1	
Energy levels for a helium atom	
Level	Energy (eV)
$E_5$	-2.2
$E_4$	-3.4
$E_3$	-6.0
$E_2$	-13.6
$E_1$ (ground state)	-54.4

- What is the maximum possible wavelength of light emitted by an electron with an orbital radius of  $8.3 \times 10^{-11}$  m? (Assume  $n = 1$ .)
- What is the power of an InGaAs laser that produces 980-nm light with a rate of  $2.5 \times 10^{15}$  photons per second?
- An electron in a mercury atom drops from 8.82 eV to 6.67 eV.
  - What is the energy of the photon emitted?
  - What is the wavelength of this photon?
  - What is the frequency of this photon?

**28 Supplemental Problems***continued*

11. What is the energy of a hydrogen atom in the  $n = 10$  Bohr orbital? How much energy must a hydrogen atom absorb to move its electron from a state where  $n = 5$  to one where  $n = 10$ ?
12. What energy is emitted when an excited hydrogen atom drops from a state where  $n = 8$  to a state where  $n = 5$ ?
13. Consider a hydrogen atom in the following situations.
  - a. What is the orbital radius of the hydrogen atom when  $n = 8$ ?
  - b. What is the orbital radius of the hydrogen atom when  $n = 5$ ?
  - c. If the radius of an hydrogen atom is  $4.77 \times 10^{-10}$  m, in what energy state is the atom?
14. What is the energy, in joules, of the photon produced when a hydrogen electron jumps from  $n = 5$  to  $n = 2$ ?
15. A hydrogen atom is in the second excited state.
  - a. What is the energy, in joules, of the photon that was emitted?
  - b. What is the wavelength of the photon emitted when the atom drops from the second excited state to the first excited state?
16. What is the frequency of light emitted when an electron transitions between two levels, if the energy emitted during the transition is  $2.96 \times 10^{-23}$  kJ?
17. What is the minimum amount of energy needed to remove an electron from a hydrogen atom? What wavelength must a photon have to remove the electron from a hydrogen atom?
18. If 1.1 eV are needed to break apart a silicon electron from its atom, what is the frequency of the photon?
19. A hydrogen atom absorbs a photon with a wavelength of 102.8 nm. What is the state of the excited atom?
20. An atom has five energy levels, with  $E_5$  being the highest and  $E_1$  being the lowest.
  - a. If the atom can make transitions between any two levels, how many spectral lines can the atom emit?
  - b. Which transition produces the highest energy photon?
21. The energy produced by the light emitted by a neon gas laser is 1.96 eV. What is the wavelength of the light produced assuming the laser is 100 percent efficient?
22. Consider a 5.0-mW, 500.0-nm laser.
  - a. How many photons per second are emitted?
  - b. How many times more photons are needed per second if you want a laser at 500.0 nm to have the same power as one at 250.0 nm? The power in a laser beam equals the energy of each photon multiplied by the number of photons emitted per second.
23. What is the lowest photon energy associated with the infrared light spectrum, which begins at 700.0 nm?
24. A fiber-optics laser light produces a wavelength of  $1.40 \times 10^3$  nm. What is the energy of the light it produces, assuming 100 percent of the electric energy delivered to the laser is converted to light energy?
25. A photon of radiation has an energy of  $4.65 \times 10^{-15}$  J. What is the wavelength of this light?

## CHAPTER

## 29

## Supplemental Problems

## Solid State Electronics

1. The atomic mass of barium is 137.3 g/mol and its density is  $3.594 \text{ g/cm}^3$ .
  - a. Calculate how many free electrons exist in a cubic centimeter of barium, which has two free electrons per atom.
  - b. Is barium a conductor, a semiconductor, or an insulator?
2. Silicon is doped with one atom of phosphorus per one million atoms of silicon. Each phosphorus atom adds one electron to the conduction band. The intrinsic ratio of pure silicon is  $1.45 \times 10^{10}$  free electrons per cubic centimeter.
  - a. There are  $4.99 \times 10^{22}$  silicon atoms per cubic centimeter. What is the density of free electrons in the doped silicon available from phosphorus?
  - b. What is the ratio of phosphorus-donated electrons to silicon-donated electrons?
  - c. Which element is primarily responsible for the conduction in the doped silicon?
3. A light emitting diode (LED) produces red light at a wavelength of 635 nm. What is the width of the forbidden gap in the diode?
4. A diode in an infrared laser used in a remote-control device for a television has a forbidden gap of 1.02 eV. What is the wavelength of the light that it emits?
5. The voltage drop across a diode is 1.2 V when it is connected in series to a  $300.0\text{-}\Omega$  resistor and a battery. If the current is 16 mA, what is the battery voltage?
6. What is the voltage drop across a diode connected to a 9.0-V battery and a  $150\text{-}\Omega$  resistor if the current is 42 mA?
7. In a diode connected to a 9.0-V battery in series with a  $625\text{-}\Omega$  resistor, the voltage drop is 3.2 V. What is the current in the diode?
8. The voltage across a glowing LED is 2.3 V when it is placed in a circuit with a 6.0-V battery and a  $150\text{-}\Omega$  resistor.
  - a. What is the voltage drop across the resistor?
  - b. What is the current through the resistor?
  - c. What is the current through the diode?
  - d. If you want to make the LED glow brighter by increasing the current to 35 mA, what size resistor should replace the  $150\text{-}\Omega$  resistor?
9. For each of these circuits at right consisting of a battery and lightbulb, will the lightbulb come on when the circuit is closed? Explain.
 

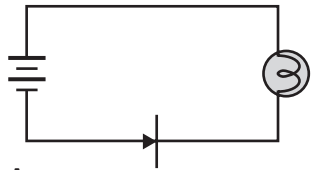

A

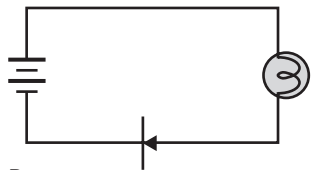

B

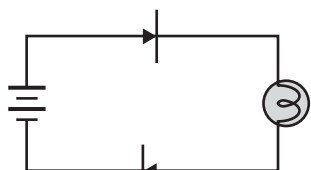

C

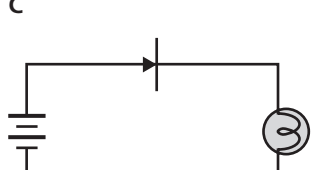

D

# 29 Supplemental Problems

continued

- 10.** For each of the following elements, indicate whether it could be used as dopant to make an  $n$ -type semiconductor, a  $p$ -type semiconductor, or neither. Use the periodic table in Appendix D.
- aluminum
  - nitrogen
  - antimony
  - carbon
  - gallium
- 11.** Iron has  $1.69 \times 10^{23}$  free electrons per  $\text{cm}^3$ . How many free  $e^-$  per iron atom exist at room temperature? The atomic mass of iron is 55.85 g/mol; the density of iron is 7.86 g/ $\text{cm}^3$ .
- 12.** The atomic mass of mercury is 200.59 g/mol; its density is 13.53 g/ $\text{cm}^3$ .
- How many free electrons exist in a cubic centimeter of mercury, if each atom contributes two electrons?
  - Using the answer to part **a**, how many atoms of mercury are there in 1.0  $\text{cm}^3$ , assuming all mercury atoms free their valence electrons?
- 13.** A 24-karat gold ring is made of 2.00 g of pure gold.
- How many free electrons are in this ring at room temperature? The density of gold is 19.32 g/ $\text{cm}^3$  and its atomic weight is 196.97. Gold has one valence electron.
  - How many atoms of gold are in 1 g of pure gold, assuming all gold atoms have freed their electrons?
- 14.** At 200 K, silicon has  $3.79 \times 10^{-18}$  free  $e^-$ /atom.
- How many free electrons are there per  $\text{cm}^3$  at this temperature? The density of silicon is 2.33 g/ $\text{cm}^3$ , and its atomic weight is 28.09 g/mol.
  - If all silicon atoms free their electrons at 200 K, how many silicon atoms are contained in 1  $\text{cm}^3$  at this temperature?
  - How many silicon atoms are contained in 1  $\text{cm}^3$  at 100 K, if silicon has  $1.85 \times 10^{-32}$  free  $e^-$ /atom and  $9.23 \times 10^{-10}$  free  $e^-/\text{cm}^3$  at this temperature?
- 15.** Each silver atom (atomic mass: 107.87) contributes one electron. Each cubic centimeter of silver contains  $5.82 \times 10^{22}$  free  $e^-$ . Calculate the density of silver at 20°C.
- 16.** Germanium (Ge) has  $2.25 \times 10^{13}$  free electrons/ $\text{cm}^3$ .
- How many atoms of germanium are there in 1  $\text{cm}^3$  at room temperature?
  - Germanium is doped with two atoms of antimony (Sb) for every million atoms of germanium. Each antimony atom donates one electron. What is the density of the free electrons?
  - How does the density of this doped germanium compare to that of intrinsic germanium?
  - Is conduction mainly by the germanium or antimony electrons?
  - Is this semiconductor an  $n$ - or  $p$ -type semiconductor? Antimony has five valence electrons.
- 17.** The potential voltage drop across a glowing LED is 1.5 V.
- What is the current through the LED when it is powered by a 12.0-V battery and a 50.0- $\Omega$  resistor?
  - What is the current through the resistor if a 6.0-V battery is used?
  - What could you do to make the LED burn more brightly?
- 18.** A diode has a voltage drop of 0.5 V with 25 mA of current passing through it. If a 460- $\Omega$  resistor is used in series, what size battery is needed for the diode?

## CHAPTER

## 30

## Supplemental Problems

## The Nucleus

1. The atomic number of tungsten is 74. It occurs predominantly as four isotopes with atomic masses of 182, 183, 184, and 186. How many neutrons are located in the nuclei of each of these isotopes?

2. Determine the number of protons and neutrons in each of these isotopes:



3. Write the nuclear equation for the transformation of a radioactive isotope of plutonium, which has 94 protons and 144 neutrons, to uranium by emission of an alpha particle.

4. Radon 212 decays by emission of an alpha particle to form polonium-208 with a half-life of 24 h. How much of a 95.0-g sample will have become polonium after three days?

5. Uranium-238 has a half-life of  $4.46 \times 10^9$  years. If Earth is 4.5 billion years old, how much of the original U-238 has not yet decayed?

6. The half-life of carbon-14 is 5730 years. If a wooden tool is measured to have  $\frac{1}{8}$  as much carbon-14 as a modern sample of wood, how old is the tool?

7. The mass of an electron is  $9.1 \times 10^{-31}$  kg.
- What is the energy equivalent of the electron's mass in joules?
  - What is the energy equivalent of the electron's mass in eV?

For questions 8 and 9, use the following values:

$$\text{mass of hydrogen atom} = 1.007825 \text{ u}$$

$$\text{mass of neutron} = 1.008665 \text{ u}$$

$$1 \text{ u} = 931.49 \text{ MeV}$$

8. The nuclear mass of deuterium, which has one proton and one neutron, is 2.014101 u.

a. Calculate the mass defect for deuterium.

b. Calculate the binding energy.

c. The nuclear mass of helium is 4.002602. How much energy, in joules, is released when two moles of deuterium nuclei fuse to form one mole of helium?

d. One ton of TNT is the equivalent of  $5.0 \times 10^9$  J. How many tons of TNT correspond to the energy released during the formation of one mole of helium by fusion of deuterium?

9. Thorium-230 has 90 protons, 140 neutrons, and a nuclear mass of 230.033127.

a. What is the mass defect of thorium-230?

b. Calculate the binding energy of the thorium nucleus.

c. What is the energy equivalent, expressed in tons of TNT, of the mass defect of a mole of thorium-230?

10. Complete these nuclear reaction equations:

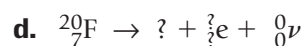
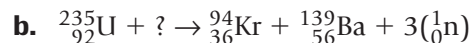
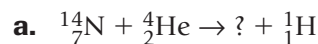

**30 Supplemental Problems***continued*

- 11.** How many protons and neutrons are in the following isotopes:  ${}_{92}^{238}\text{U}$ ,  ${}_{106}^{263}\text{Sg}$ ,  ${}_{90}^{234}\text{Th}$ ,  ${}_{4}^{7}\text{Be}$ ?
- 12.** Zinc has four isotopes with mass numbers of 54, 63, 70, and 81. How many neutrons are there in the nuclei of each of isotope?
- 13.** What are the symbols for the five isotopes of nitrogen, each with the following number of neutrons in the nucleus: 6, 7, 8, 9, 10?
- 14.** Write the nuclear equation for the decay of uranium-238 by emission of an  $\alpha$  particle.
- 15.** Write the equation for the  $\beta$  decay of  ${}_{6}^{14}\text{C}$ .
- 16.** Write the nuclear equation for the transmutation of a beryllium-7 atom by the emission of a  $\beta$  particle and an antineutrino.
- 17.** How much of a 50.0-g sample of radium-226 will remain after 30.5 years? The half-life of radium-226 is 1662 years.
- 18.** The isotope  ${}_{53}^{131}\text{I}$  has a half-life of 8.07 days. If you have 50.0 g, what will be the mass of iodine-131 that remains two weeks from today?
- 19.** Suppose 50.0 kg of plutonium-242 waste were buried on January 1, 1982. How much of the waste will exist on January 1, 2982? The half-life of plutonium-242 is  $3.79 \times 10^5$  years.
- 20.** The atomic mass of  ${}_{3}^{6}\text{Li}$  is 6.0151214 u, and the atomic mass of  ${}_{3}^{7}\text{Li}$  is 7.0160030 u.
- a.** Calculate the mass defect of two isotopes of lithium,  ${}_{3}^{6}\text{Li}$  and  ${}_{3}^{7}\text{Li}$ . The mass of one proton is 1.007825 u, and the mass of one neutron is 1.008665 u.
- b.** Calculate the binding energies of the two lithium isotopes. The binding energy of 1 u = 931.49 MeV.
- 21.** A zinc isotope,  ${}_{30}^{64}\text{Zn}$ , has an atomic mass of 63.929145 u. What is the mass defect of this isotope? The mass of one proton is 1.007825 u and the mass of one neutron is 1.008665 u.
- 22.** An iron isotope has 26 protons and 28 neutrons and a mass of 53.939613 u. What is the mass defect of this isotope? The mass of one proton is 1.007825 u and the mass of one neutron is 1.008665 u.
- 23.** Complete the following nuclear equations using a periodic table:
- a.**  ${}_{1}^{1}\text{H} + {}_{4}^{9}\text{Be} \rightarrow {}_{3}^{6}\text{Li} + ?$
- b.**  ${}_{13}^{27}\text{Al} + {}_{2}^{4}\text{He} \rightarrow {}_{15}^{30}\text{P} + ?$
- c.**  ${}_{2}^{4}\text{He} + {}_{6}^{12}\text{C} \rightarrow {}_{7}^{15}\text{N} + ?$
- d.**  ${}_{92}^{235}\text{U} + {}_{0}^{1}\text{n} = {}_{54}^{140}\text{Xe} + ? + {}_{2}^{1}\text{n}$
- 24.** What is the charge of a particle that has two protons and one neutron? Each proton has two up quarks, u, with a charge of  $+2/3 e$  each, and one down quark, d, with a charge of  $-1/3 e$ . Each neutron is made up of one up quark and two down quarks.